

National Exams - December 2002
98-Agric-B8 Food Process Engineering (Part 1)

3 hours duration

Notes:

1. If doubt exists as to the interpretation of any question, the candidate is urged to submit with the answer paper, a clear statement of any assumptions made.
2. Any non-communicating calculator is permitted. This is an Open book exam. Note to candidates you must indicate the type of calculator being used, i.e. write the name and model designation of the calculator, on the first left hand sheet, of the exam work book.
3. Complete the questions as indicated on the paper. Some choices are provided.
4. Marks for each question are given at the end of the question.

I. Food Freezing and freeze concentration
Do any one out of the following two questions

1. A spherical shaped food product with a diameter of 18 cm has a freezing time of 5 hours at a freezing medium temperature of -30°C . (a) How long would it take to freeze 15 cm diameter product in the same freezer? (b) Would it be worth while increasing the air velocity in the freezer to obtain faster freezing? Take $h \propto (\text{velocity})^{0.8}$. (c) How much would freezing at -40°C reduce the freezing time? Use any equation or method, and assume any unknown if you require. (15% marks)

2. Five-centimetre potato cubes are individually quick frozen (IQF) in a blast freezer operating at -40°C and with a surface heat transfer coefficient of $30 \text{ W}/(\text{m}^2\cdot\text{K})$. If the initial freezing temperature of the potato is -1.0°C and the density is $1180 \text{ kg}/\text{m}^3$, calculate the freezing time for the cube using Plank's equation. If the cubes are packed into a cardboard carton measuring $20 \text{ cm} \times 10 \text{ cm} \times 10 \text{ cm}$, calculate the freezing time (replace $1/h$ in the Plank's equation with $1/h + x/k_1$, where $x = \text{cardboard thickness} = 1.5 \text{ mm}$, and $k_1 = \text{thermal conductivity of the cardboard} = 0.07 \text{ W}/(\text{m}\cdot\text{K})$). Also calculate the freezing time of 2.5 cm cubes. The thermal conductivity of the frozen potato = $2.5 \text{ W}/(\text{m}\cdot\text{K})$, and latent heat of freezing of potato = $274\,000 \text{ J}/\text{kg}$. (15% marks)

II. Thermal processing

Do any two questions out of the following three questions

3. Calculate the thermal process F-value from the temperature-time plot provided using the graphical method, $z = 18^{\circ}\text{F}$. (20% marks)

4. In a given product, a microorganism has a D value of 3 min at 250°F and a z value of 20°F . If the process was calculated at 280°F for a z value 10°F , how many minutes of heating is required for a 5 D process? What would be the actual probability of spoilage from an initial inoculum of 100 spores/can for the above 280°F process ($z = 18^{\circ}\text{F}$) if the organism actually has a z value of 20°F when heated with the product? (20% marks)

5. A biological indicator unit (BIU) which consists of a vial containing a spore suspension and installed at the geometric centre of a can to check the validity of a thermal process for the food. The canned food has an f_h value of 30 min and a j value of 1.8. Of the 1000 spores originally in the BIU, an analysis after the process showed a survival of 12 spores. The spores in the BIU have a D_0 of 2.3 min and a z value of 14°F . The process was carried out at 248°F from an initial temperature of 140°F . Calculate (a) the process time, and (b) the sterilizing value ($\log N_0/N$) of the process of *C. botulinum* having a D_0 of 0.21 min and a z of 18°F . (20% marks)

III. Evaporator

Do any one question out of the following two questions

6. The double effect evaporator in figure is used to concentrate $1000 \text{ kg}/\text{h}$ of whey from 6% solids to 40% solids. Calculate the rate of steam consumption (m_s , kg/h) and the mass flow rates of vapours from each effect (W_1 , W_2). Neglect boiling point elevation and sensible heat of the

For Problem #3

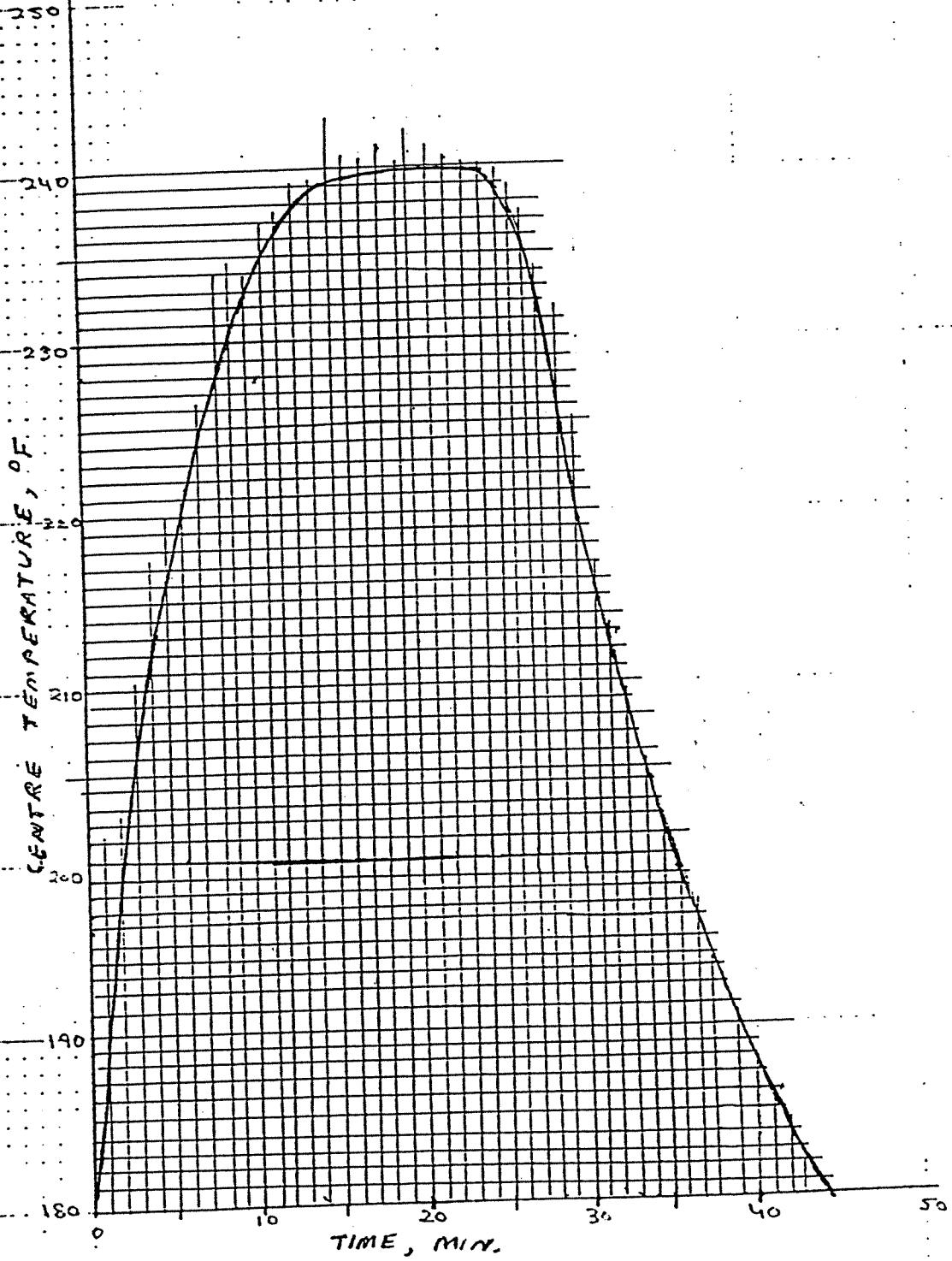

food material in both effects. Consider equal heat transfer in both effects. Also calculate steam economy. (20% marks)

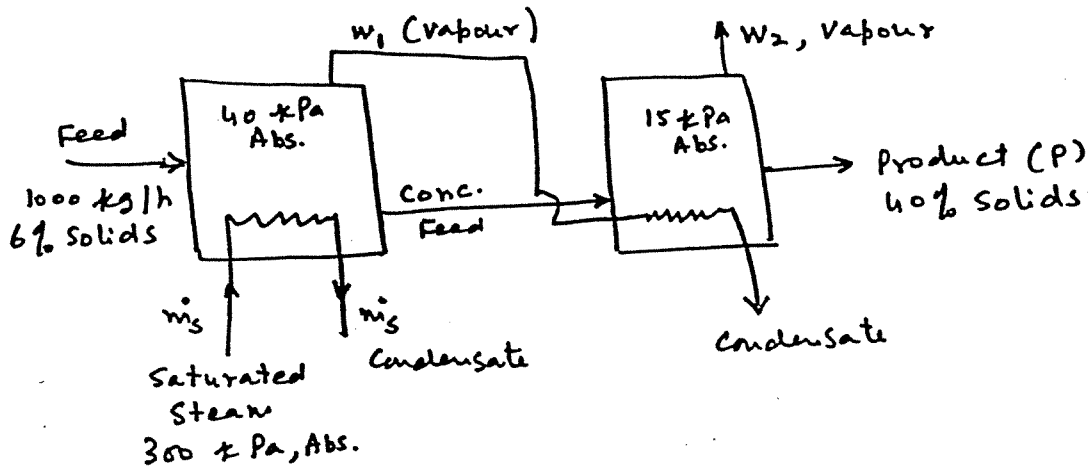

7. A double effect evaporator is shown in the figure where the feed passes through two pre-heaters. Calculate the steam economy (kg water/kg steam) of the evaporator neglecting the boiling point elevation. Specific heat for the feed and product is $4.18 \text{ kJ/(kg } ^\circ\text{C)}$. (20% marks)

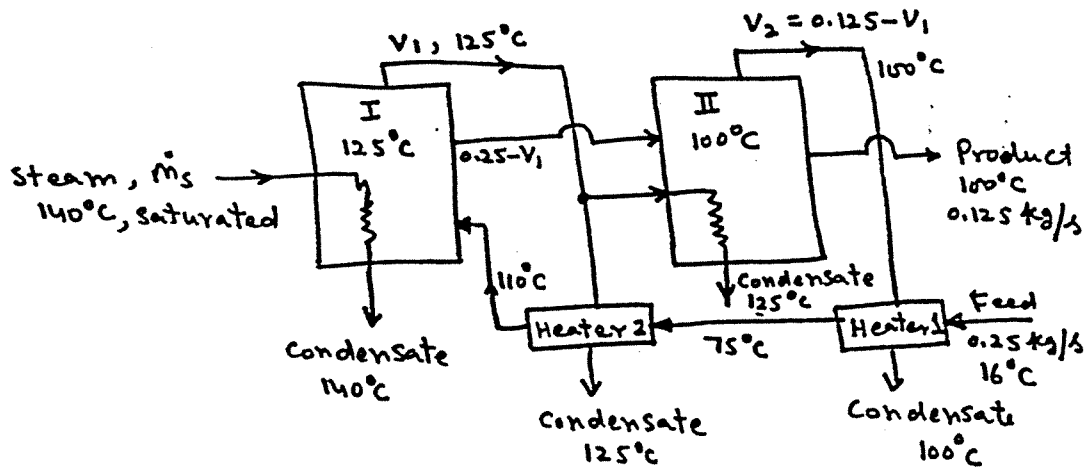

IV. Heat transfer

Do one question from 8 and 9, and another from 10 and 11

8. What shape container of the same radius or of the same characteristic dimension would heat faster and why: an infinite slab, an infinite cylinder and a sphere? (10% marks)

9. Explain why food products often freeze in less time than is required to thaw? (10% marks)

10. A batch of milk, volume 250 litres, is heated from an initial temperature of 4°C in a steam jacketed, agitated, vessel of heating surface area of 1.5 m^2 . (a) Calculate the time taken to heat

the milk to 70°C , if the overall heat transfer coefficient is $800 \text{ W}/(\text{m}^2 \text{ }^{\circ}\text{C})$. The specific heat of the milk is $3900 \text{ J}/(\text{kg } ^{\circ}\text{C})$ and its density is $1030 \text{ kg}/\text{m}^3$. The steam temperature is 130°C . (b) Suggest two possible changes in the processing conditions to reduce the heating time by 25%. Show your calculations for the suggested changes. (15% marks)

11. A process has to be developed to heat a meat sausage in a smokehouse. The sausage can be considered a finite cylinder of 30 cm length and 10 cm diameter. Initial temperature of the sausage is 2°C and smokehouse temperature is 97°C . Estimate the temperature of the sausage at its geometric centre 2 h after it has been placed in the smokehouse. Thermal conductivity of the sausage is $0.48 \text{ W}/(\text{m } ^{\circ}\text{C})$, its density is $1070 \text{ kg}/\text{m}^3$, and its specific heat is $3350 \text{ J}/(\text{kg } ^{\circ}\text{C})$. The heat transfer coefficient in the smokehouse to the sausage surface is $1200 \text{ W}/(\text{m}^2 \text{ } ^{\circ}\text{C})$. (15% marks)

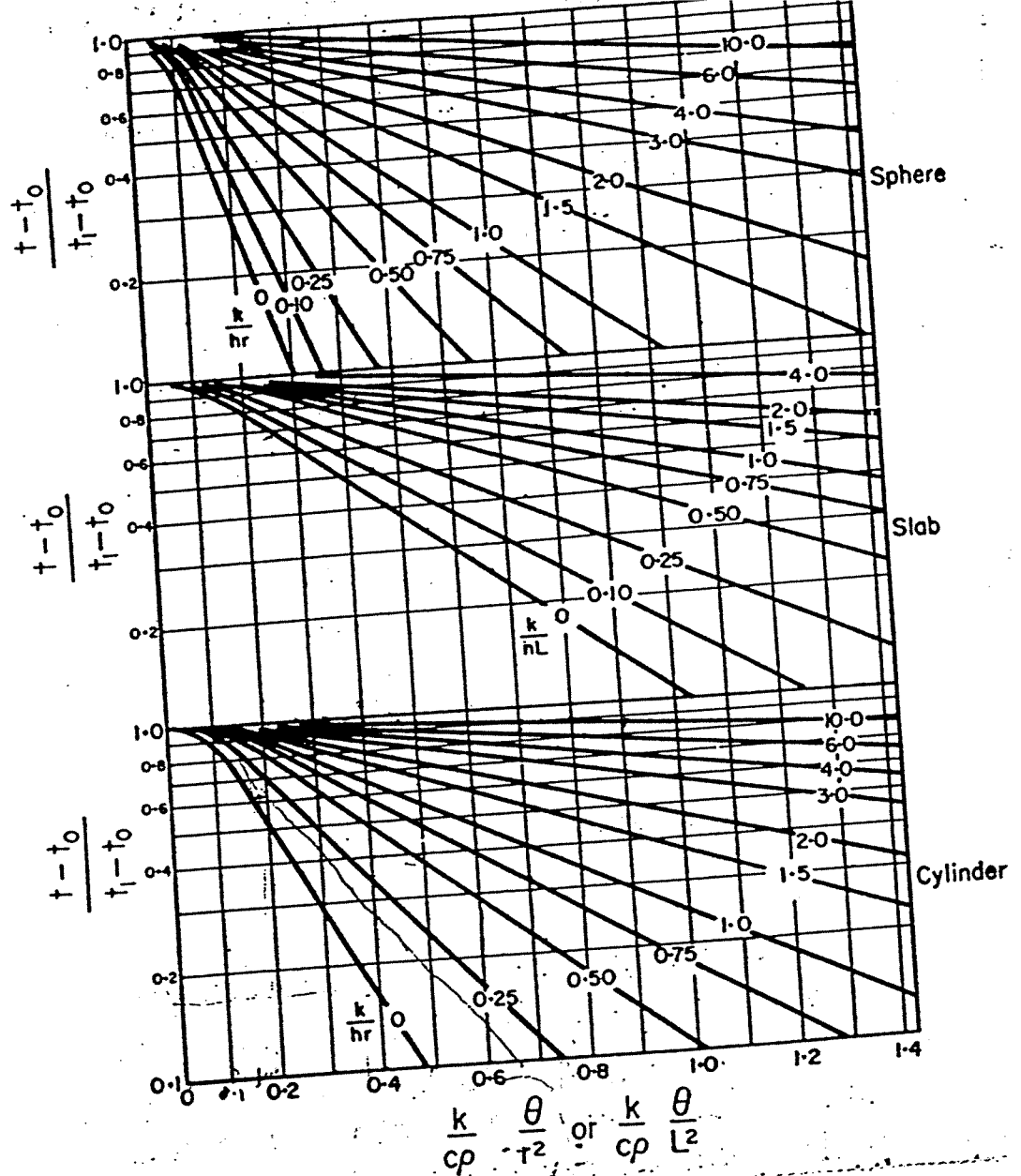

Table 9.12. f_h/U vs. g Table Used for Thermal Process Calculations by Stumbo's Procedure

$\frac{f_h}{U}$	$z = 14$		$z = 18$		$z = 22$	
	g	$\frac{\Delta g}{\Delta j}$	g	$\frac{\Delta g}{\Delta j}$	g	$\frac{\Delta g}{\Delta j}$
0.2	0.000091	0.0000118	0.0000509	0.0000168	0.0000616	0.0000226
0.3	0.00175	0.00059	0.0024	0.00066	0.00282	0.00106
0.4	0.0122	0.0038	0.0162	0.0047	0.020	0.0067
0.5	0.0396	0.0111	0.0506	0.0159	0.065	0.0197
0.6	0.0876	0.0224	0.109	0.036	0.143	0.040
0.7	0.155	0.036	0.189	0.066	0.25	0.069
0.8	0.238	0.053	0.287	0.103	0.38	0.105
0.9	0.334	0.07	0.400	0.145	0.527	0.147
1.0	0.438	0.009	0.523	0.192	0.685	0.196
2.0	1.56	0.37	1.93	0.68	2.41	0.83
3.0	2.53	0.70	3.26	1.05	3.98	1.44
4.0	3.33	1.03	4.41	1.34	5.33	1.97
5.0	4.02	1.32	5.40	1.59	6.51	2.39
6.0	4.63	1.56	6.25	1.82	7.53	2.75
7.0	5.17	1.77	7.00	2.05	8.44	3.06
8.0	5.67	1.95	7.66	2.27	9.26	3.32
9.0	6.13	2.09	8.25	2.48	10.00	3.55
10	6.55	2.22	8.78	2.69	10.67	3.77
15	8.29	2.68	10.88	3.57	13.40	4.60
20	9.63	2.96	12.40	4.28	15.30	5.50
25	10.7	3.18	13.60	4.80	16.9	6.10
30	11.6	3.37	14.60	5.30	18.2	6.70
35	12.4	3.50	15.50	5.70	19.3	7.20
40	13.1	3.70	16.30	6.00	20.3	7.60
45	13.7	3.80	17.00	6.20	21.1	8.0
50	14.2	4.00	17.7	6.40	21.9	8.3
60	15.1	4.3	18.9	6.80	23.2	9.0
70	15.9	4.5	19.9	7.10	24.3	9.5
80	16.5	4.8	20.8	7.30	25.3	9.8
90	17.1	5.0	21.6	7.60	26.2	10.1
100	17.6	5.2	22.3	7.80	27.0	10.4
150	19.5	6.1	25.2	8.40	30.3	11.4
200	20.8	6.7	27.1	9.10	32.7	12.1

Source: Based on f_h/U vs. g tables in Stumbo, C. R. 1973. *Thermobacteriology in Food Processing*, 2nd ed. Academic Press, New York.

To use for values of j other than 1, solve for g_j as follows:

$$g_j = j_{j-1} + (j - 1)(\Delta g/\Delta j)$$

Example: g for $(f_h/U) = 20$ and $j = 1.4$ at $z = 18$.

$$g_{j=1.4} = 12.4 + (0.4)(4.28) = 14.11$$

Reprinted from: Toledo, R. T. 1980. *Fundamentals of Food Process Engineering*, 1st ed. AVI Pub. Co. Westport, CT.

Appendix B Steam Tables
Saturated Steam--Temperature Table

Temp., °C <i>T</i>	Press., kPa <i>P</i>	Specific Volume, m ³ /kg		Internal Energy, kJ/kg			Enthalpy, kJ/kg			Entropy, kJ/kg		
		Sat. Liquid <i>v_f</i>	Sat. Vapor <i>v_g</i>	Sat. Liquid <i>u_f</i>	Eavp. <i>u_{fg}</i>	Sat. Vapor <i>u_g</i>	Sat. Liquid <i>h_f</i>	Evap. <i>h_{fg}</i>	Sat. Vapor <i>h_g</i>	Sat. Liquid <i>s_f</i>	Evap. <i>s_{fg}</i>	Sat. Vapor <i>s_g</i>
0.01	0.61	0.001000	206.14	00.00	2375.3	2375.3	00.01	2501.3	2501.4	0.0000	9.1562	9.1562
5	0.87	0.001000	147.12	20.97	2361.3	2382.3	20.98	2489.6	2510.6	0.0761	8.9496	9.0257
10	1.23	0.001000	106.38	42.00	2347.2	2389.2	42.01	2477.7	2519.8	0.1510	8.7498	8.9008
15	1.70	0.001001	77.93	62.99	2333.1	2396.1	62.99	2465.9	2528.9	0.2245	8.5569	8.7814
20	2.34	0.001002	57.79	83.95	2319.0	2402.9	83.96	2454.1	2538.1	0.2966	8.3706	8.6672
25	3.17	0.001003	43.36	104.88	2304.9	2409.8	104.89	2442.3	2547.2	0.3674	8.1905	8.5580
30	4.25	0.001004	32.89	125.78	2290.8	2416.6	125.79	2430.5	2556.3	0.4369	8.0164	8.4533
35	5.63	0.001006	25.22	146.67	2276.7	2423.4	146.68	2418.6	2565.3	0.5053	7.8478	8.3531
40	7.38	0.001008	19.52	167.56	2262.6	2430.1	167.57	2406.7	2574.3	0.5725	7.6845	8.2570
45	9.59	0.001010	15.26	188.44	2248.4	2436.8	188.45	2394.8	2583.2	0.6387	7.5261	8.1648
50	12.35	0.001012	12.03	209.32	2234.2	2443.5	209.33	2382.7	2592.1	0.7038	7.3725	8.0763
55	15.76	0.001015	9.568	230.21	2219.9	2450.1	230.23	2370.7	2600.9	0.7679	7.2234	7.9913
60	19.94	0.001017	7.671	251.11	2205.5	2456.6	251.13	2358.5	2609.6	0.8312	7.0784	7.9096
65	25.03	0.001020	6.197	272.02	2191.1	2463.1	272.06	2346.2	2618.3	0.8935	6.9375	7.8310
70	31.19	0.001023	5.042	292.95	2176.6	2469.6	292.98	2333.8	2626.8	0.9549	6.8004	7.7553
75	38.58	0.001026	4.131	313.90	2162.0	2475.9	313.93	2321.4	2635.3	1.0155	6.6669	7.6824
80	47.39	0.001029	3.407	334.86	2147.4	2482.2	334.91	2308.8	2643.7	1.0753	6.5369	7.6122
85	57.83	0.001033	2.828	355.84	2132.6	2488.4	355.90	2296.0	2651.9	1.1343	6.4102	7.5445
90	70.14	0.001036	2.361	376.85	2117.7	2494.5	376.92	2283.2	2660.1	1.1925	6.2866	7.4791
95	84.55	0.001040	1.982	397.88	2102.7	2500.6	397.96	2270.2	2668.1	1.2500	6.1659	7.4159

Saturated Steam--Temperature Table (Continued)

Temp., °C <i>T</i>	Pres., MPa <i>P</i>	Specific Volume, m ³ /kg		Internal Energy, kJ/kg			Enthalpy, kJ/kg			Entropy, kJ/kg		
		Sat. Liquid <i>v_f</i>	Sat. Vapor <i>v_g</i>	Sat. Liquid <i>u_f</i>	Eavp. <i>u_{fg}</i>	Sat. Vapor <i>u_g</i>	Sat. Liquid <i>h_f</i>	Evap. <i>h_{fg}</i>	Sat. Vapor <i>h_g</i>	Sat. Liquid <i>s_f</i>	Evap. <i>s_{fg}</i>	Sat. Vapor <i>s_g</i>
100	0.10132	0.001044	1.6729	418.94	2087.6	2506.5	419.04	2257.0	2676.1	1.3069	6.0480	7.3549
105	0.12082	0.001048	1.4194	440.02	2072.3	2512.4	440.15	2243.7	2683.8	1.3630	5.9328	7.2958
110	0.14327	0.001052	1.2102	461.14	2057.0	2518.1	461.30	2230.2	2691.5	1.4185	5.8202	7.2387
115	0.16906	0.001056	1.0366	482.30	2041.4	2523.7	482.48	2216.5	2699.0	1.4734	5.7100	7.1833
120	0.19853	0.001060	0.8919	503.50	2025.8	2529.3	503.71	2202.6	2706.3	1.5276	5.6020	7.1296
125	0.2321	0.001065	0.7706	524.74	2009.9	2534.6	524.99	2188.5	2713.5	1.5813	5.4962	7.0775
130	0.2701	0.001070	0.6685	546.02	1993.9	2539.9	546.31	2174.2	2720.5	1.6344	5.3925	7.0269
135	0.3130	0.001075	0.5822	567.35	1977.7	2545.0	567.69	2159.6	2727.3	1.6870	5.2907	6.9777
140	0.3613	0.001080	0.5089	588.74	1961.3	2550.0	589.13	2144.7	2733.9	1.7391	5.1908	6.9299
145	0.4154	0.001085	0.4463	610.18	1944.7	2554.9	610.63	2129.6	2740.3	1.7907	5.0926	6.8833
150	0.4758	0.001091	0.3928	631.68	1927.9	2559.5	632.20	2114.3	2746.5	1.8418	4.9960	6.8379

Saturated Steam--Temperature Table (continued)

T	P	v_f	v_g	u_f	u_{fg}	u_g	h_f	h_{fg}	h_g	s_f	s_{fg}	s_g
155	0.5431	0.001096	0.3468	653.24	1910.8	2564.1	653.84	2098.6	2752.4	1.8925	4.9010	6.7935
160	0.6178	0.001102	0.3071	674.87	1893.5	2568.4	675.55	2082.6	2758.1	1.9427	4.8075	6.7502
165	0.7005	0.001108	0.2727	696.56	1876.0	2572.5	697.34	2066.2	2763.5	1.9925	4.7153	6.7078
170	0.7917	0.001114	0.2428	718.33	1858.1	2576.5	719.21	2049.5	2768.7	2.0419	4.6244	6.6663
175	0.8920	0.001121	0.2168	740.17	1840.0	2580.2	741.17	2032.4	2773.6	2.0909	4.5347	6.6256
180	1.0021	0.001127	0.19405	762.09	1821.6	2583.7	763.22	2015.0	2778.2	2.1396	4.4461	6.5857
185	1.1227	0.001134	0.17409	784.10	1802.9	2587.0	785.37	1997.1	2782.4	2.1879	4.3586	6.5465
190	1.2544	0.001141	0.15654	806.19	1783.8	2590.0	807.62	1978.8	2786.4	2.2359	4.2720	6.5079
195	1.3978	0.001149	0.14105	828.37	1764.4	2592.8	829.98	1960.0	2790.0	2.2835	4.1863	6.4698
200	1.5538	0.001157	0.12736	850.65	1744.7	2595.3	852.45	1940.7	2793.2	2.3309	4.1014	6.4323
205	1.7230	0.001164	0.11521	873.04	1724.5	2597.5	875.04	1921.0	2796.0	2.3780	4.0172	6.3952
210	1.9062	0.001173	0.10441	895.53	1703.9	2599.5	897.76	1900.7	2798.5	2.4248	3.9337	6.3585
215	2.104	0.001181	0.09479	918.14	1682.9	2601.1	920.62	1879.9	2800.5	2.4714	3.8507	6.3221
220	2.318	0.001190	0.08619	940.87	1661.5	2602.4	943.62	1858.5	2802.1	2.5178	3.7683	6.2861
225	2.548	0.001199	0.07849	963.73	1639.6	2603.3	966.78	1836.5	2803.3	2.5639	3.6863	6.2503
230	2.795	0.001209	0.07158	986.74	1617.2	2603.9	990.12	1813.8	2804.0	2.6099	3.6047	6.2146
235	3.06	0.001219	0.06537	1009.89	1594.2	2604.1	1013.62	1790.5	2804.2	2.6558	3.5233	6.1791
240	3.344	0.001229	0.05976	1033.21	1570.8	2604.0	1037.32	1766.5	2803.8	2.7015	3.4422	6.1437
245	3.648	0.001240	0.05471	1056.71	1546.7	2603.4	1061.23	1741.7	2803.0	2.7472	3.3612	6.1083
250	3.973	0.001251	0.05013	1080.39	1522.0	2602.4	1085.36	1716.2	2801.5	2.7927	3.2802	6.0730
255	4.319	0.001263	0.04598	1104.28	1496.7	2600.9	1109.73	1689.8	2799.5	2.8383	3.1992	6.0375
260	4.688	0.001276	0.04221	1128.39	1470.6	2599.0	1134.37	1662.5	2796.9	2.8838	3.1181	6.0019
265	5.081	0.001289	0.03877	1152.74	1443.9	2596.6	1159.28	1634.4	2793.6	2.9294	3.0368	5.9662
270	5.499	0.001302	0.03564	1177.36	1416.3	2593.7	1184.51	1605.2	2789.7	2.9751	2.9551	5.9301
275	5.942	0.001317	0.03279	1202.25	1387.9	2590.2	1210.07	1574.9	2785.0	3.0208	2.8730	5.8938
280	6.412	0.001332	0.03017	1227.46	1358.7	2586.1	1235.99	1543.6	2779.6	3.0668	2.7903	5.8571
285	6.909	0.001348	0.02777	1253.00	1328.4	2581.4	1262.31	1511.0	2773.3	3.1130	2.7070	5.8199
290	7.436	0.001366	0.02557	1278.92	1297.1	2576.0	1289.07	1477.1	2766.2	3.1594	2.6227	5.7821
295	7.993	0.001384	0.02354	1305.20	1264.7	2569.9	1316.30	1441.8	2758.1	3.2062	2.5375	5.7437
300	8.581	0.001404	0.02167	1332.00	1231.0	2563.0	1344.00	1404.9	2749.0	3.2534	2.4511	5.7045
305	9.202	0.001425	0.019948	1359.30	1195.9	2555.2	1372.40	1366.4	2738.7	3.3010	2.3633	5.6643
310	9.856	0.001447	0.018350	1387.10	1159.4	2546.4	1401.30	1326.0	2727.3	3.3493	2.2737	5.6230
315	10.547	0.001472	0.016867	1415.50	1121.1	2536.6	1431.00	1283.5	2714.5	3.3982	2.1821	5.5804
320	11.274	0.001499	0.015488	1444.60	1080.9	2525.5	1461.50	1238.6	2700.1	3.4480	2.0882	5.5362
330	12.845	0.001561	0.012996	1505.30	993.7	2498.9	1525.30	1140.6	2665.9	3.5507	1.8909	5.4417
340	14.586	0.001638	0.010797	1570.30	894.3	2464.6	1594.20	1027.9	2622.0	3.6594	1.6763	5.3357
350	16.513	0.001740	0.008813	1641.90	776.6	2418.4	1670.60	893.4	2563.9	3.7777	1.4335	5.2112
360	18.651	0.001893	0.006945	1725.20	626.3	2351.5	1760.50	720.5	2481.0	3.9147	1.1379	5.0526
370	21.03	0.002213	0.004925	1844.00	384.5	2228.5	1890.50	441.6	2332.1	4.1106	0.6865	4.7971
374.14	22.09	0.003155	0.003155	2029.60	0.0	2029.6	2099.30	0.0	2099.3	4.4298	0.0000	4.4298

From Van Wylen, G.J., and Sonntag, R.E., 1986. *Fundamentals of Classical Thermodynamics*. Wiley, New York. Reprinted with permission of John Wiley & Sons, Inc.

Superheated Vapor

T	P = 0.010 MPa (45.81)				P = 0.050 MPa (81.33)				P = 0.10 MPa (99.63)			
	v	u	h	s	v	u	h	s	v	u	h	s
Sat.	14.674	2437.9	2584.7	8.1502	3.240	2483.9	2645.9	7.5939	1.6940	2506.1	2675.5	7.3594
50	14.869	2443.9	2592.6	8.1749								
100	17.196	2515.5	2687.5	8.4479	3.418	2511.6	2682.5	7.6947	1.6958	2506.7	2676.2	7.3614
150	19.512	2587.9	2783.0	8.6882	3.889	2585.6	2780.1	7.9401	1.9364	2582.8	2776.4	7.6134
200	21.825	2661.3	2879.5	8.9038	4.356	2659.9	2877.7	8.1580	2.172	2658.1	2875.3	7.8343
250	24.136	2736.0	2977.3	9.1002	4.820	2735.0	2976.0	8.3556	2.406	2733.7	2974.3	8.0333
300	26.445	2812.1	3076.5	9.2813	5.284	2811.3	3075.5	8.5373	2.639	2810.4	3074.3	8.2158
400	31.063	2968.9	3279.6	9.6077	6.209	2968.5	3278.9	8.8642	3.103	2967.9	3278.2	8.5435
500	35.679	3132.3	3489.1	9.8978	7.134	3132.0	3488.7	9.1546	3.565	3131.6	3488.1	8.8342
600	40.295	3302.5	3705.4	10.1608	8.057	3302.2	3705.1	9.4178	4.028	3301.9	3704.7	9.0976
700	44.911	3479.6	3928.7	10.4028	8.981	3479.4	3928.5	9.6599	4.490	3479.2	3928.2	9.3398
800	49.526	3663.8	4159.0	10.6281	9.904	3663.6	4158.9	9.8852	4.952	3663.5	4158.6	9.5652
900	54.141	3855.0	4396.4	10.8396	10.828	3854.9	4396.3	10.0967	5.414	3854.8	4396.1	9.7767
1000	58.757	4053.0	4640.6	11.0393	11.751	4052.9	4640.5	10.2964	5.875	4052.8	4640.3	9.9764
1100	63.372	4257.5	4891.2	11.2287	12.674	4257.4	4891.1	10.4859	6.337	4257.3	4891.0	10.1659
1200	67.987	4467.9	5147.8	11.4091	13.597	4467.8	5147.7	10.6662	6.799	4467.7	5147.6	10.3463
1300	72.602	4683.7	5409.7	11.5811	14.521	4683.6	5409.6	10.8382	7.260	4683.5	5409.5	10.5183

T	P = 0.20 MPa (120.23)				P = 0.30 MPa (133.55)				P = 0.40 MPa (143.63)			
	v	u	h	s	v	u	h	s	v	u	h	s
Sat.	0.8857	2529.5	2706.7	7.1272	0.6058	2543.6	2725.3	6.9919	0.4625	2553.6	2738.6	6.8959
150	0.9596	2576.9	2768.8	7.2795	0.6339	2570.8	2761.0	7.0778	0.4708	2564.5	2752.8	6.9299
200	1.0803	2654.4	2870.5	7.5066	0.7163	2650.7	2865.6	7.3115	0.5342	2646.8	2860.5	7.1706
250	1.1988	2731.2	2971.0	7.7086	0.7964	2728.7	2967.6	7.5166	0.5951	2726.1	2964.2	7.3789
300	1.3162	2808.6	3071.8	7.8926	0.8753	2806.7	3069.3	7.7022	0.6548	2804.8	3066.8	7.5662
400	1.5493	2966.7	3276.6	8.2218	1.0315	2965.6	3275.0	8.0330	0.7726	2964.4	3273.4	7.8985
500	1.7814	3130.8	3487.1	8.5133	1.1867	3130.0	3486.0	8.3251	0.8893	3129.2	3484.9	8.1913
600	2.013	3301.4	3704.0	8.7770	1.3414	3300.8	3703.2	8.5892	1.0055	3300.2	3702.4	8.4558
700	2.244	3478.8	3927.6	9.0194	1.4957	3478.4	3927.1	8.8319	1.1215	3477.9	3926.5	8.6987
800	2.475	3663.1	4158.2	9.2449	1.6499	3662.9	4157.8	9.0576	1.2372	3662.4	4157.3	8.9244
900	2.706	3854.5	4395.8	9.4566	1.8041	3854.2	4395.4	9.2692	1.3529	3853.9	4395.1	9.1362
1000	2.937	4052.5	4640.0	9.6563	1.9581	4052.3	4639.7	9.4690	1.4685	4052.0	4639.4	9.3360
1100	3.168	4257.0	4890.7	9.8458	2.1121	4256.8	4890.4	9.6585	1.5840	4256.5	4890.2	9.5256
1200	3.399	4467.5	5147.3	10.0262	2.2661	4467.2	5147.1	9.8389	1.6996	4467.0	5146.8	9.7060
1300	3.630	4683.2	5409.3	10.1982	2.4201	4683.0	5409.0	10.0110	1.8151	4682.8	5408.8	9.8780

T	P = 0.50 MPa (151.86)				P = 0.60 MPa (158.85)				P = 0.80 MPa (170.43)			
	v	u	h	s	v	u	h	s	v	u	h	s
Sat.	0.3749	2561.2	2748.7	6.8213	0.3157	2567.4	2756.8	6.7600	0.2404	2576.8	2769.1	6.6628
200	0.4249	2642.9	2855.4	7.0592	0.3520	2638.9	2850.1	6.9665	0.2608	2630.6	2839.3	6.8158
250	0.4744	2723.5	2960.7	7.2709	0.3938	2720.9	2957.2	7.1816	0.2931	2715.5	2950.0	7.0384
300	0.5226	2802.9	3064.2	7.4599	0.4344	2801.0	3061.6	7.3724	0.3241	2797.2	3056.5	7.2328
350	0.5701	2882.6	3167.7	7.6329	0.4742	2881.2	3165.7	7.5464	0.3544	2878.2	3161.7	7.4089

Superheated Vapor (continued)

400	0.6173	2963.2	3271.9	7.7938	0.5137	2962.1	3270.3	7.7079	0.3843	2959.7	3267.1	7.5716
500	0.7109	3128.4	3483.9	8.0873	0.5920	3127.6	3482.8	8.0021	0.4433	3126.0	3480.6	7.8673
600	0.8041	3299.6	3701.7	7.3522	0.6697	3299.1	3700.9	8.2674	0.5018	3297.9	3699.4	8.1333
700	0.8969	3477.5	3925.9	8.5952	0.7472	3477.0	3925.3	8.5107	0.5601	3476.2	3942.2	8.3770
800	0.9896	3662.1	4156.9	8.8211	0.8245	3661.8	4156.5	8.7367	0.6181	3661.1	4155.6	8.6033
900	1.0822	3853.6	4394.7	9.0329	0.9017	3853.4	4394.4	8.9486	0.6761	3852.8	4393.7	8.8153
1000	1.1747	4051.8	4639.1	9.2328	0.9788	4051.5	4638.8	9.1485	0.7340	4051.0	4638.2	9.0153
1100	1.2672	4256.3	4889.9	9.4224	1.0559	4256.1	4889.6	9.3381	0.7919	4255.6	4889.1	9.2050
1200	1.3596	4466.8	5146.6	9.6029	1.1330	4466.5	5146.3	9.5185	0.8497	4466.1	5145.9	9.3855
1300	1.4521	4682.5	5408.6	9.7749	1.2101	4682.3	5408.3	9.6906	0.9076	4681.8	5407.9	9.5575

T	P = 1.00 MPa (179.91)				P = 1.20 MPa (187.99)				P = 1.40 MPa (195.07)			
	v	u	h	s	v	u	h	s	v	u	h	s
Sat.	0.19444	2583.6	2778.1	6.5865	0.16333	2588.8	2784.8	6.5233	0.14084	2592.8	2790.0	6.4693
200	0.2060	2621.9	2827.9	6.6940	0.16930	2612.8	2815.9	6.5898	0.14302	2603.1	2803.3	6.4975
250	0.2327	2709.9	2942.6	6.9247	0.19234	2704.2	2935.0	6.8294	0.16350	2698.3	2927.2	6.7467
300	0.2579	2793.2	3151.2	7.1229	0.2138	2789.2	3045.8	7.0317	0.18228	2785.2	3040.4	6.9534
350	0.2825	2875.2	3157.7	7.3011	0.2345	2872.2	3153.6	7.2121	0.2003	2869.2	3149.5	7.1360
400	0.3066	2957.3	3263.9	7.4651	0.2548	2954.9	3260.7	7.3774	0.2178	2952.5	3257.5	7.3026
500	0.3541	3124.4	3478.5	7.7622	0.2946	3122.8	3476.3	7.6759	0.2521	3121.1	3474.1	7.6027
600	0.4011	3296.8	3697.9	8.0290	0.3339	3295.6	3696.3	7.9435	0.2860	3294.4	3694.8	7.8710
700	0.4478	3475.3	3923.1	8.2731	0.3729	3474.4	3922.0	8.1881	0.3195	3473.6	3920.8	8.1160
800	0.4943	3660.4	4154.7	8.4996	0.4118	3659.7	4153.8	8.4148	0.3528	3659.0	4153.0	8.3431
900	0.5407	3852.2	4392.9	8.7118	0.4505	3851.6	4392.2	8.6272	0.3861	3851.1	4391.5	8.5556
1000	0.5871	4050.5	4637.6	8.9119	0.4892	4050.0	4637.0	8.8274	0.4192	4049.5	4636.4	8.7559
1100	0.6335	4255.1	4888.6	9.1017	0.5278	4254.6	4888.0	9.0172	0.4524	4254.1	4887.5	8.9457
1200	0.6798	4465.6	5145.4	9.2822	0.5665	4465.1	5144.9	9.1977	0.4855	4464.7	5144.4	9.1262
1300	0.7261	4681.3	5407.4	9.4543	0.6051	4680.9	5407.0	9.3698	0.5186	4680.4	5406.5	9.2984

T	P = 1.60 MPa (201.41)				P = 1.80 MPa (207.15)				P = 2.00 MPa (212.42)			
	v	u	h	s	v	u	h	s	v	u	h	s
Sat.	0.12380	2596.0	2794.0	6.4218	0.11042	2598.4	2797.1	6.3794	0.09963	2600.3	2799.5	6.3409
225	0.13287	2644.7	2857.3	6.5518	0.11673	2636.6	2846.7	6.4808	0.10377	2628.3	2835.8	6.4147
250	0.14184	2692.3	2919.2	6.6732	0.12497	2686.0	2911.0	6.6066	0.11144	2679.6	2902.5	6.5453
300	0.15862	2781.1	3034.8	6.8844	0.14021	2776.9	3029.2	6.8226	0.12547	2772.6	3023.5	6.7664
350	0.17456	2866.1	3145.4	7.0694	0.15457	2863.0	3141.2	7.0100	0.13857	2859.8	3137.0	6.9563
400	0.19005	2950.1	3254.2	7.2374	0.16847	2947.7	3250.9	7.1794	0.15120	2945.2	3247.6	7.1271
500	0.2203	3119.5	3472.0	7.5390	0.19550	3117.9	3469.8	7.4825	0.17568	3116.2	3467.6	7.4317
600	0.2500	3293.3	3693.2	7.8080	0.2220	3292.1	3691.7	7.7523	0.19960	3290.9	3690.1	7.7024
700	0.2794	3472.7	3919.7	8.0535	0.2482	3471.8	3918.5	7.9983	0.2232	3470.9	3917.4	7.9487
800	0.3086	3658.3	4152.1	8.2808	0.2742	3657.6	4151.2	8.2258	0.2467	3657.0	4150.3	8.1765
900	0.3377	3850.5	4390.8	8.4935	0.3001	3849.9	4390.1	8.4386	0.2700	3849.3	4389.4	8.3895
1000	0.3668	4049.0	4635.8	8.6938	0.3260	4048.5	4635.2	8.6391	0.2933	4048.0	4634.6	8.5901
1100	0.3958	4253.7	4887.0	8.8837	0.3518	4253.2	4886.4	8.8290	0.3166	4252.7	4885.9	8.7800
1200	0.4248	4464.2	5143.9	9.0643	0.3776	4463.7	5143.4	9.0096	0.3398	4463.3	5142.9	8.9607
1300	0.4538	4679.9	5406.0	9.2364	0.4034	4679.5	5405.6	9.1818	0.3631	4679.0	5405.1	9.1329

T	P = 2.50 MPa (223.99)				P = 3.00 MPa (233.90)				P = 3.50 MPa (242.60)			
	v	u	h	s	v	u	h	s	v	u	h	s
Sat.	0.07998	2603.1	2803.1	6.2575	0.06668	2604.1	2804.2	6.1869	0.05707	2603.7	2803.4	6.1253
225	0.08027	2605.6	2806.3	6.2639								
250	0.08700	2662.6	2880.1	6.4085	0.07058	2644.0	2855.8	6.2872	0.05872	2623.7	2829.2	6.1749
300	0.09890	2761.6	3008.8	6.6438	0.08114	2750.1	2993.5	6.5390	0.06842	2738.0	2977.5	6.4461
350	0.10976	2851.9	3126.3	6.8403	0.09053	2843.7	3115.3	6.7428	0.07678	2835.3	3104.0	6.6579
400	0.12010	2939.1	3239.3	7.0148	0.09936	2932.8	3230.9	6.9212	0.08453	2926.4	3222.3	6.8405
450	0.13014	3025.5	3350.8	7.1746	0.10787	3020.4	3344.0	7.0834	0.09196	3015.3	3337.2	7.0052
500	0.13998	3112.1	3462.1	7.3234	0.11619	3108.0	3456.5	7.2338	0.09918	3103.0	3450.9	7.1572
600	0.15930	3288.0	3686.3	7.5960	0.13243	3285.0	3682.3	7.5085	0.11324	3282.1	3678.4	7.4339
700	0.17832	3468.7	3914.5	7.8435	0.14838	3466.5	3911.7	7.7571	0.12699	3464.3	3908.8	7.6837
800	0.19716	3655.3	4148.2	8.0720	0.16414	3653.5	4145.9	7.9862	0.14056	3651.8	4143.7	7.9134
900	0.2159	3847.9	4387.6	8.2853	0.17980	3846.5	4385.9	8.1999	0.15402	3845.0	4384.1	8.1276
1000	0.2346	4046.7	4633.1	8.4861	0.19541	4045.4	4631.6	8.4009	0.16743	4044.1	4630.1	8.3288
1100	0.2532	4251.5	4884.6	8.6762	0.21098	4250.3	4883.3	8.5912	0.18080	4249.2	4881.9	8.5192
1200	0.2718	4462.1	5141.7	8.8569	0.22652	4460.9	5140.5	8.7720	0.19415	4459.8	5139.3	8.7000
1300	0.2905	4677.8	5404.0	9.0291	0.24206	4676.6	5402.8	8.9442	0.20749	4675.5	5401.7	8.8723

Compressed Liquid

T	P = 5.00 MPa (263.99)				P = 10.00 MPa (311.06)				P = 15.00 MPa (342.24)			
	v	u	h	s	v	u	h	s	v	u	h	s
Sat.	0.0012859	1147.8	1154.2	2.9202	0.0014524	1393.0	1407.6	3.3596	0.0016581	1585.6	1610.5	3.6848
0	0.0009977	0.04	5.04	0.0001	0.0009952	0.09	10.04	0.0002	0.0009928	0.15	15.05	0.0004
20	0.0009995	83.65	88.65	0.2956	0.0009972	83.36	93.33	0.2945	0.0009950	83.06	97.99	0.2934
40	0.0010056	166.95	171.97	0.5705	0.0010034	166.35	176.38	0.5686	0.0010013	165.76	180.78	0.5666
60	0.0010149	250.23	255.30	0.8285	0.0010127	249.36	259.49	0.8258	0.0010105	248.51	263.67	0.8232
80	0.0010268	333.72	338.85	1.0720	0.0010245	332.59	342.83	1.0688	0.0010222	331.48	346.81	1.0656
100	0.0010410	417.52	422.72	1.3030	0.0010385	416.12	426.50	1.2992	0.0010361	414.74	430.28	1.2955
120	0.0010576	501.80	507.09	1.5233	0.0010549	500.08	510.64	1.5189	0.0010522	498.40	514.19	1.5145
140	0.0010768	586.76	592.15	1.7343	0.0010737	584.68	595.42	1.7292	0.0010707	582.66	598.72	1.7242
160	0.0010988	672.62	678.12	1.9375	0.0010953	670.13	681.08	1.9317	0.0010918	667.71	684.09	1.9260
180	0.0011240	759.63	765.25	2.1341	0.0011199	756.65	767.84	2.1275	0.0011159	753.76	770.50	2.1210
200	0.0011530	848.1	853.9	2.3255	0.0011480	844.5	856.0	2.3178	0.0011433	841.0	858.2	2.3104
220	0.0011866	938.4	944.4	2.5128	0.0011805	934.1	945.9	2.5039	0.0011748	929.9	947.5	2.4953
240	0.0012264	1031.4	1037.5	2.6979	0.0012187	1026.0	1038.1	2.6872	0.0012114	1020.8	1039.0	2.6771
260	0.0012749	1127.9	1134.3	2.8830	0.0012645	1121.1	1133.7	2.8699	0.0012550	1114.6	1133.4	2.8576
280					0.0013216	1220.9	1234.1	3.0548	0.0013084	1212.5	1232.1	3.0393
300					0.0013972	1328.4	1342.3	3.2469	0.0013770	1316.6	1337.3	3.2260
320									0.0014724	1431.1	1453.2	3.4247
340									0.0016311	1567.5	1591.9	3.6546

From Van Wylen, G.J., and Sonntag, R.E., 1986. *Fundamentals of Classical Thermodynamics*. Wiley, New York. Reprinted with permission of John Wiley & Sons, Inc.