

National Exams December 2002

98-BS-6: Mechanics of Materials

3 hours duration

Notes:

1. If doubt exists as to the interpretation of any question, the candidate is urged to submit with the answer paper a clear statement of any assumptions made.
2. Candidates may use one of two calculators, the Casio or Sharp approved models.

This is a Closed Book exam. However candidates are permitted to bring the following into the examination room:

- ONE aid sheet 8.5" x 11" hand-written on both sides containing notes and formulae. Example problems and solutions to problems are not allowed!
3. Any five questions (out of 8 given) constitute a complete paper. Only the first five questions as they appear in your answer book will be marked.
 4. All questions are of equal value.

Question 1

A short 900 mm high reinforced concrete column carries a compressive load of $P = 1500$ kN as shown. The column is 350 mm x 350 mm in cross-section and reinforced with 4 steel bars each having an effective diameter of 35.7 mm. Assume an elastic modulus of 200 GPa for the steel and 30 GPa for the concrete. The steel has an allowable stress of 240 MPa and the concrete has an allowable stress of 16 MPa.

- [13 marks] (i) Determine the stresses in the concrete and steel, and
- [4 marks] (ii) the corresponding displacement of the column.
- [3 marks] (iii) What is the maximum allowable load that can be carried by the column?

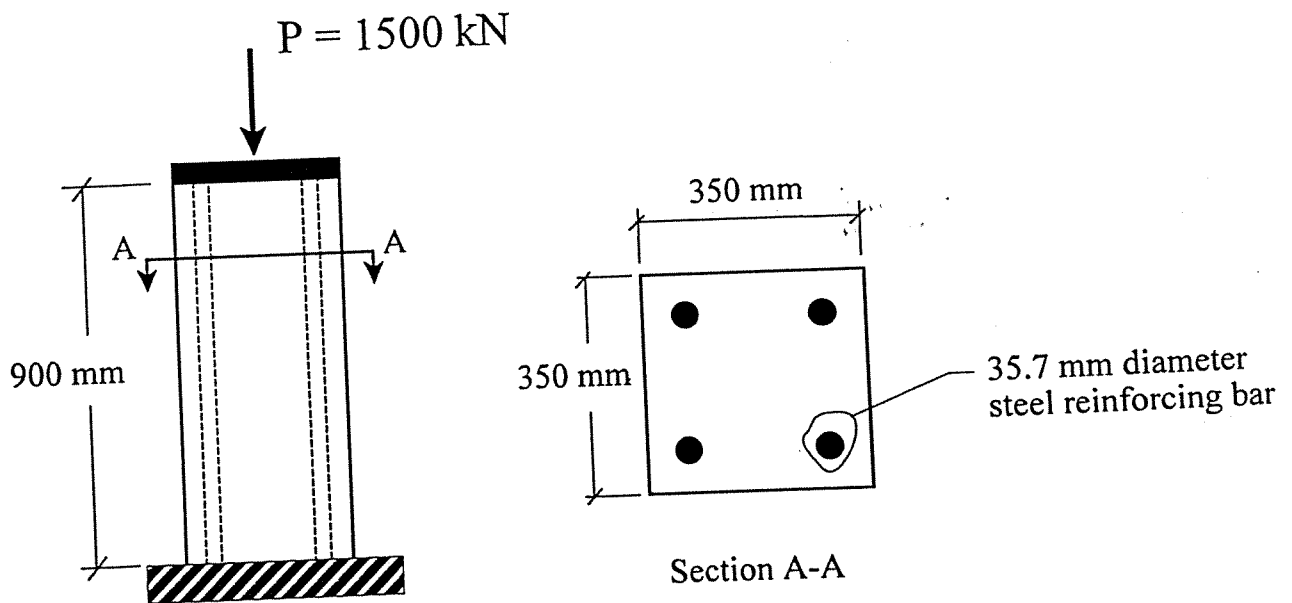

Question 2

Part of the stepped circular shaft shown below is hollow, and the two torques are applied in opposite directions as indicated. The shaft is made of steel with a shear modulus of $G = 75 \text{ GPa}$ and yield stress of $\tau_y = 150 \text{ MPa}$.

- [12 marks] (i) determine the maximum shear stress in the shaft, and sketch the corresponding variation of shear stress along the shaft radius.
- [6 marks] (ii) find the angle of twist at the end of the shaft and give your answer in degrees.
- [2 marks] (iii) indicate whether the shaft will fail, assuming that the step in the shaft is constructed with a fillet having a radius sufficient to reduce the torsional stress concentration factor to a value of 1.3.

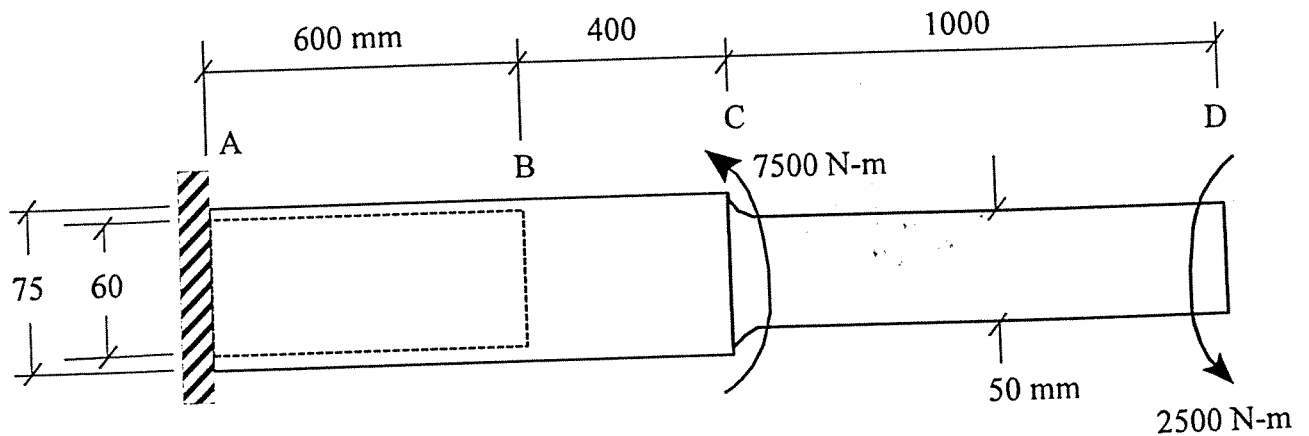

Question 3

The beam below is loaded by a weight of $W = 20 \text{ kN}$ which is applied through a cable that is attached to the vertical arm at D and passes over a small frictionless pulley at C.

[18 marks] Construct a shear force and a bending moment diagram for beam ABC. Remember to label all critical points and show your work by indicating exactly how you obtained your answers.

[2 marks] Indicate whether part of beam ABC is subjected to an axial load.

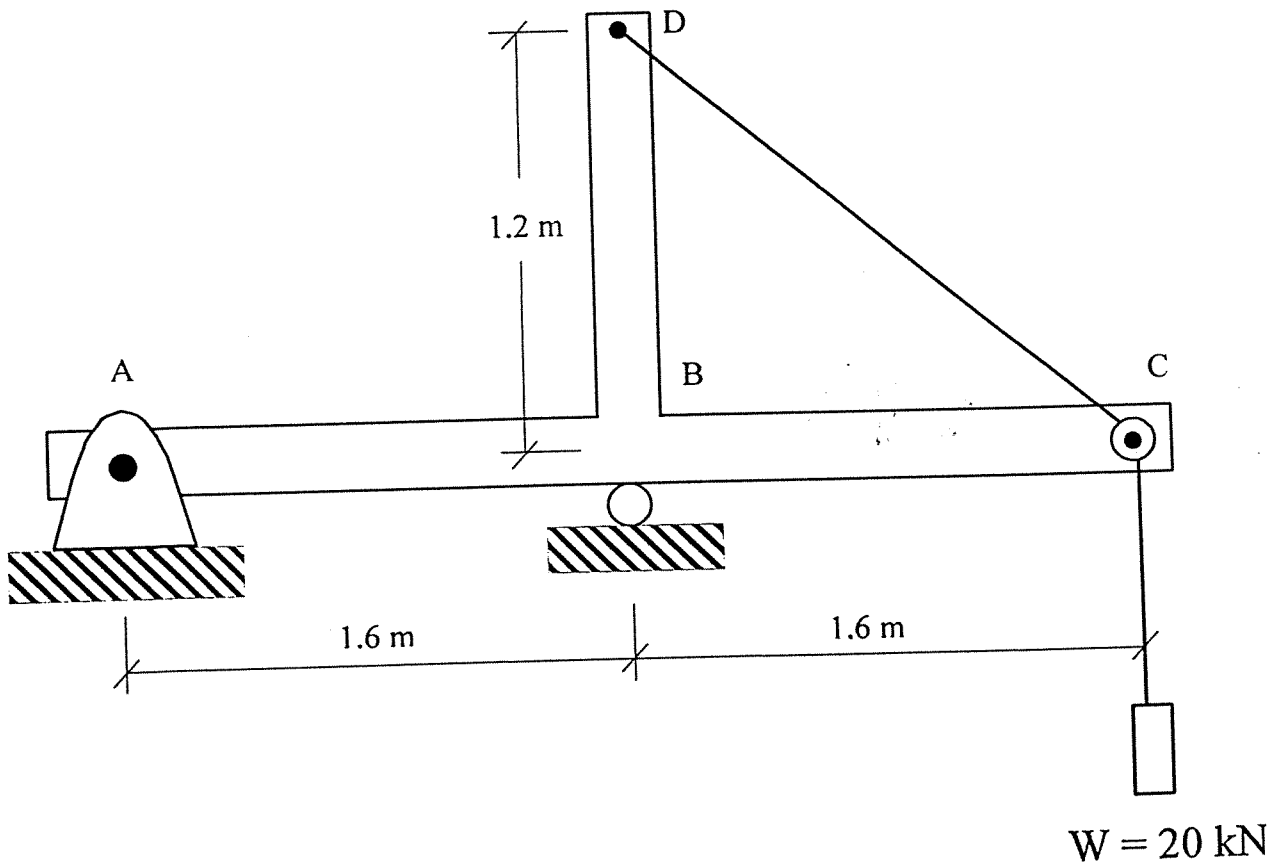

Question 4

A cantilever beam is subjected to a triangularly distributed load having a maximum intensity of $q_0 = 50 \text{ kN/m}$. The beam cross-section has the form of a steel channel with bending about the horizontal axis as shown. Assume an elastic modulus of $E = 200 \text{ GPa}$ and yield stress of $\sigma_y = 350 \text{ MPa}$.

[20 marks] Determine the maximum normal stresses and maximum shear stress in the beam.

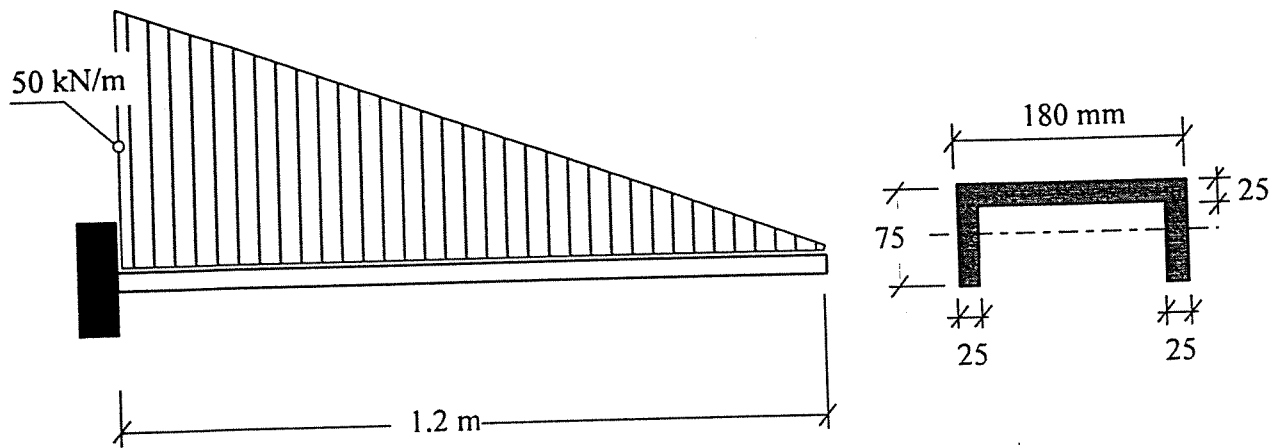

Question 5

A thin plastic sheet used to line a settling pond is subjected to axial stresses of $\sigma_x = 5.5$ MPa and $\sigma_y = 2.75$ MPa as well as a shear stress of $\tau_{xy} = -1.4$ MPa as shown below.

[18 marks] Use the Mohr's circle solution (*not* the transformation equations) to determine the normal and shear stresses acting on a seam inclined at an angle of 15° to the vertical. Show your answer on an inclined element.

[2 marks] Why is it necessary to calculate the stress acting on the seam?

Note that credit will **only** be given for a **solution using Mohr's circle**. Stress transformation equations can only be used to check your answer.

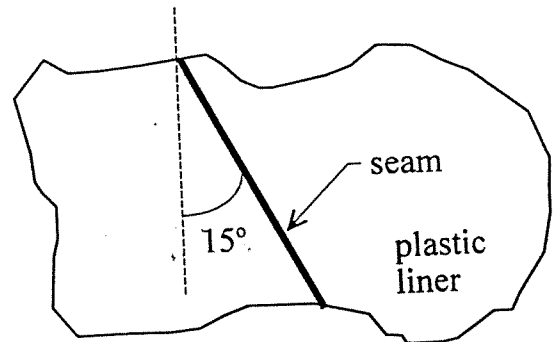
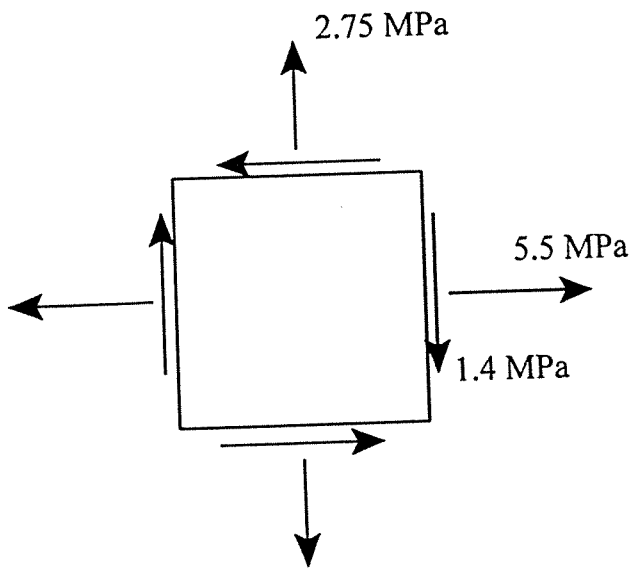

Question 6

[20 marks]

A rectangular beam (100 mm wide x 200 mm high) is subjected to an axial load of 1000 kN and transverse load of 20 kN as shown.

Determine the distribution of normal stress and shear stress acting over the cross-section of the beam at B. Show your answer on a sketch!

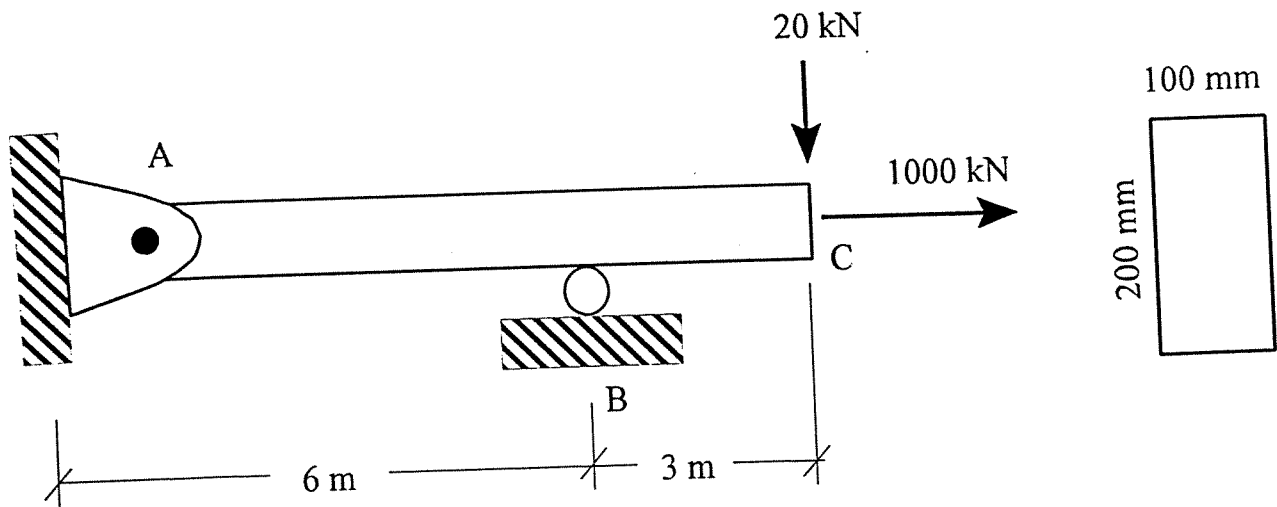

Question 7

[20 marks]

A 1.2 m long cantilever beam supports a triangular distributed load of maximum intensity $q_0 = 50 \text{ kN/m}$. The beam is made with a steel channel section having the dimensions given. See question 4 for material properties.

Using the method of integration, determine the vertical deflection and slope at the free end of the beam.

Does this beam satisfy deflection criteria given that the maximum allowable deflection is equal to $L/180$ for a structural steel cantilever beam?

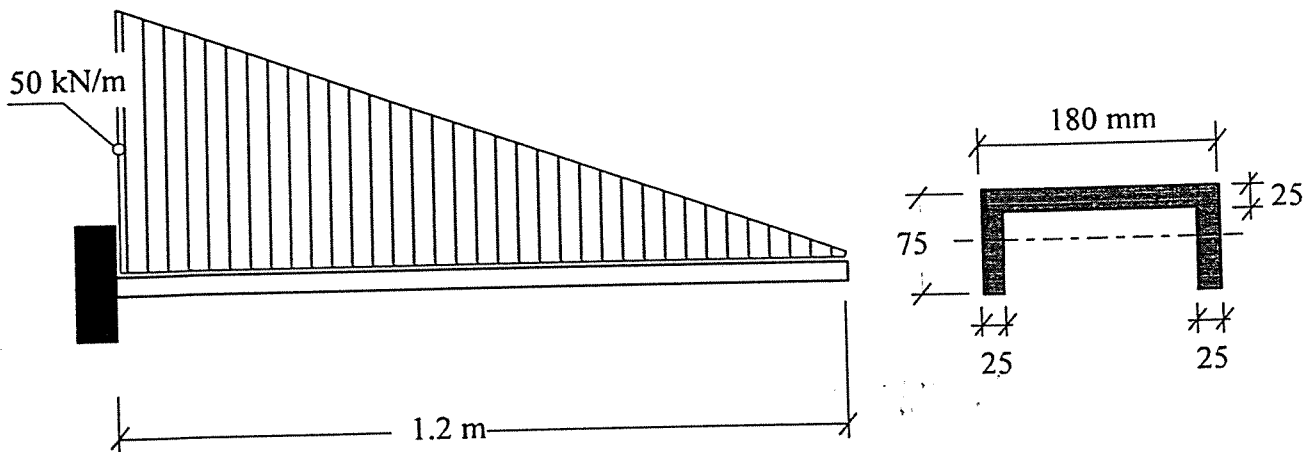

Question 8

[20 marks]

A 3 m long pipe of circular cross-section is fixed at the base and pinned at the top to a horizontal beam designed to support a load of $P = 200$ kN. The pipe has an outside diameter of 115 mm, and is made of an aluminum alloy with an elastic modulus of 70 GPa and an allowable normal stress of 250 MPa.

Determine the wall thickness needed for the aluminum pipe using a safety factor with respect to buckling of 2.5, and consider in-plane buckling only.

Note: $I_{\text{circle}} = \frac{\pi r^4}{4}$

