

NATIONAL EXAMS DECEMBER 2002

98-CIV-B1 ADVANCED STRUCTURAL ANALYSIS

3 HOURS DURATION

NOTES:

1. If doubt exists as to the interpretation of any question, the candidate is urged to submit with the answer paper a clear statement of any assumption made.
2. Candidates may use one of two calculators, a Casio FX-991 or a Sharp EL-540; otherwise, this is a CLOSED BOOK Examination.
3. Answer BOTH questions #1, and #2. Answer ONLY TWO of questions #3, #4, or #5. Answer ONLY TWO of questions #6, #7, #8 OR #9. SIX questions constitute a complete paper.
4. The marks assigned to each question are shown in the left margin.

FRONT PAGE

QUESTIONS #1 AND #2 MUST BE ANSWERED.

1. Schematically show the shear force and bending moment diagrams for the following structures. All members have the same EI and are inextensible.

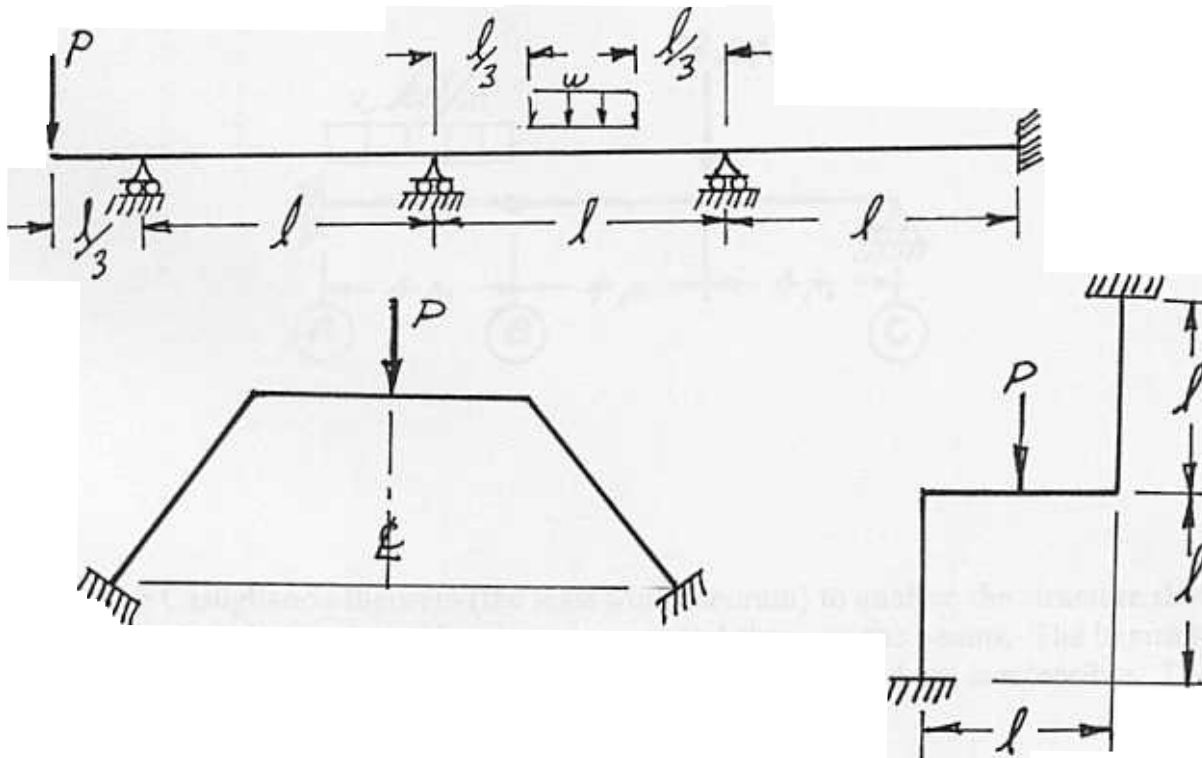

2. For the two-beam structure shown below, schematically show the influence lines for the moment and shear listed below as a) and b). Calculate and label the ordinate with the maximum absolute value on each influence line.
- Moment over support B.
 - Shear force immediately right of support B.

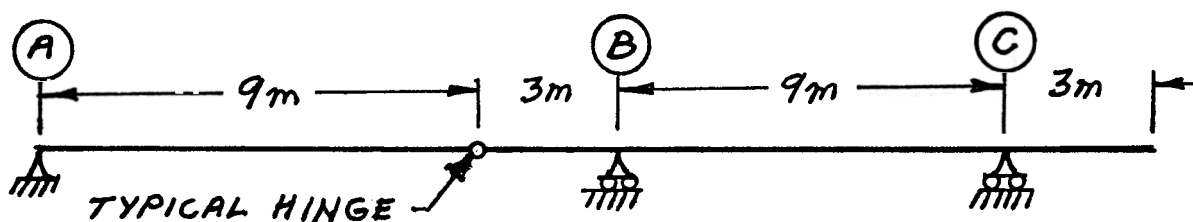

SELECT AND ANSWER TWO QUESTION ONLY FROM QUESTIONS 3, 4, OR 5.

- (18) 3. Use Castigliano's theorem to determine the vertical deflection at joint B of the beam structure shown below. The EI value for both members is $2.56 \times 10^4 \text{ kN.m}^2$ and both are inextensible.

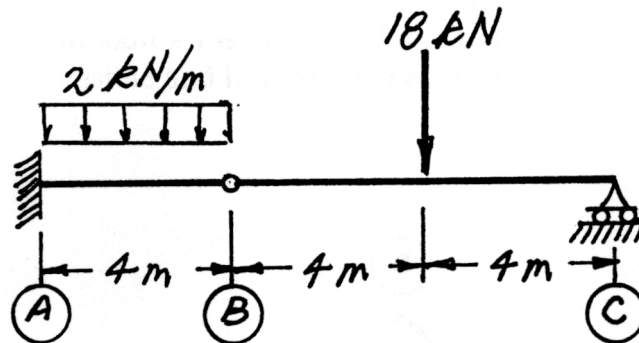

- (18) 4. Use Castigliano's theorem (the least work theorem) to analyze the structure shown. Calculate the maximum bending moment and shear on the beams. The beams have $EI = 10000 \text{ kN.m}^2$; they are continuous from A to C and are inextensible. The tension bars have $EA = 8250 \text{ kN}$.

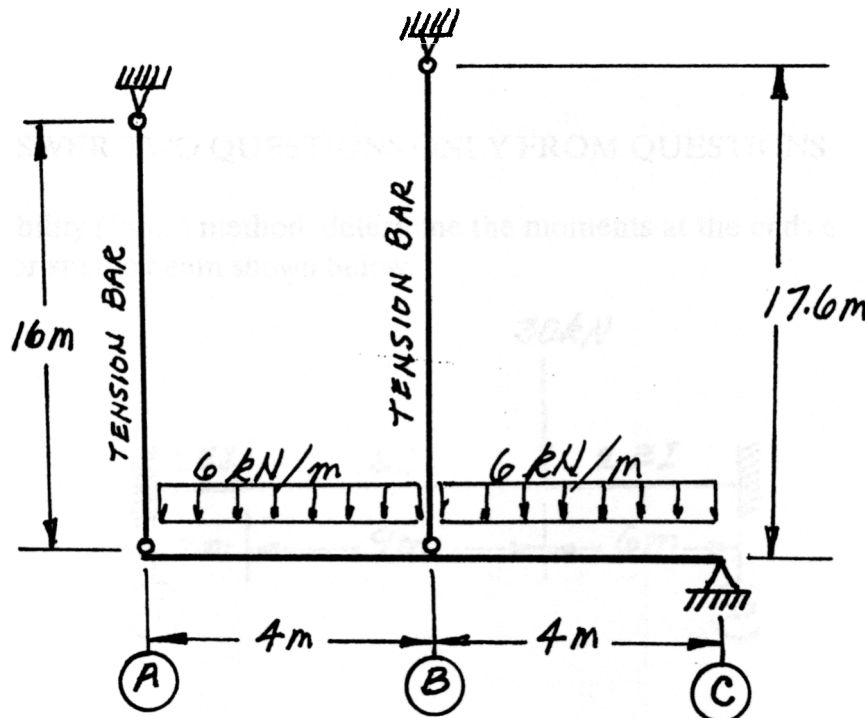

SELECT AND ANSWER TWO QUESTIONS ONLY FROM QUESTIONS 3, 4, OR 5

- (18) 5. Use the slope-deflection or moment-distribution method to analyze the frame structure shown. Draw shear and bending moment diagrams. Indicate on both diagrams the magnitude of maximum and minimum ordinates. There are no loads on the structure, but joint #1 is moved 9.9 mm to the left. Both members of the structure are inextensible and have the same EI value which is $1.8 \times 10^5 \text{ kN.m}^2$.

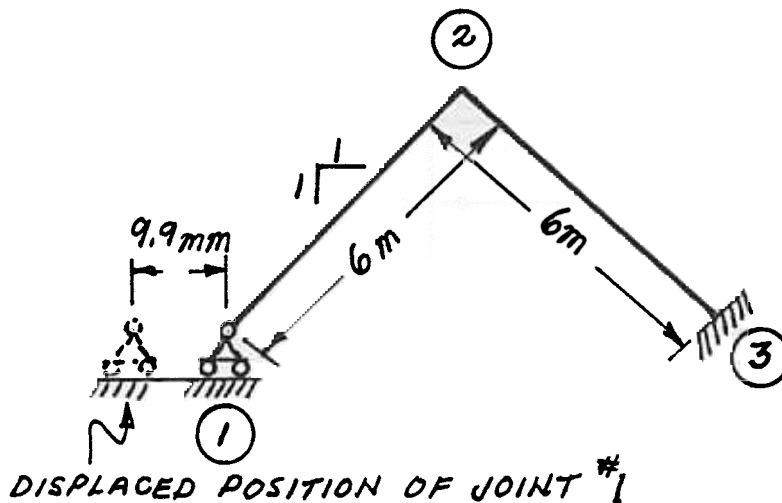

SELECT AND ANSWER TWO QUESTIONS ONLY FROM QUESTIONS 6, 7, 8 OR 9.

- (22) 6. Using a flexibility (force) method, determine the moments at the ends of the fixed-ended, non-prismatic beam shown below.

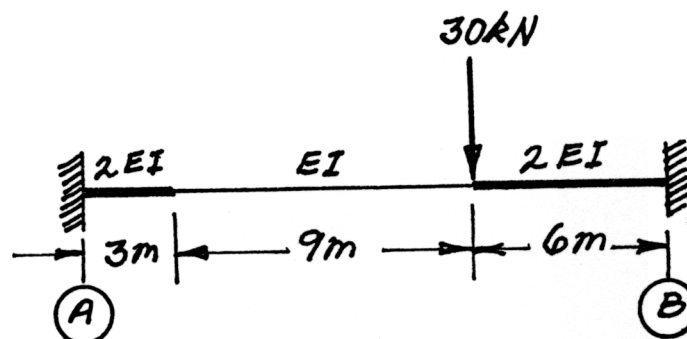

SELECT AND ANSWER TWO QUESTIONS ONLY FROM QUESTIONS 6, 7, 8 OR 9.

- (22) 7. Using the slope-deflection method or the moment-distribution method, analyze the structure shown below. In addition to the loads shown on the sketch below, joint #4 settles (moves downward) 12 mm. Plot shear force and bending moment diagrams. For each member on each diagram, indicate the magnitude of the maximum positive and negative values. All members are inextensible and have the same EI value which is $1.6 \times 10^5 \text{ kN.m}^2$.

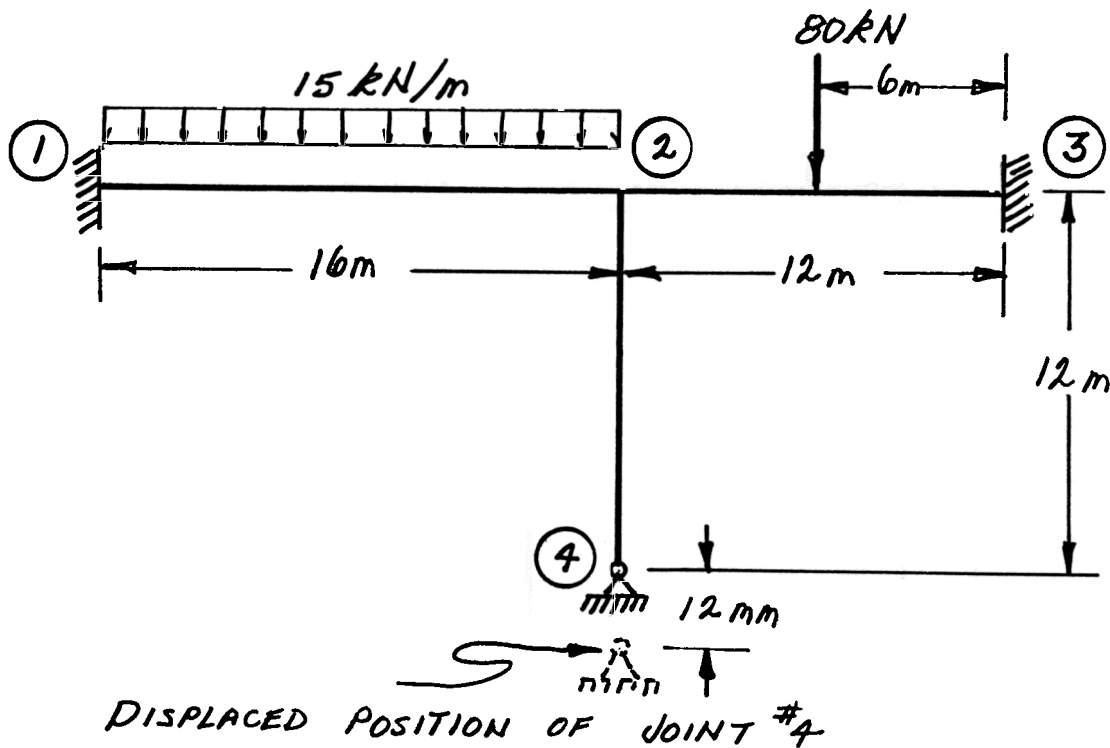

SELECT AND ANSWER TWO QUESTIONS ONLY FROM QUESTIONS 6, 7, 8 OR 9.

- (22) 8. Using the slope-deflection method or the moment-distribution method, analyze the structure shown. Draw shear force and bending moment diagrams. On each diagram indicate the magnitudes of the maximum positive and negative values for each member. Both members have the same EI and are inextensible.

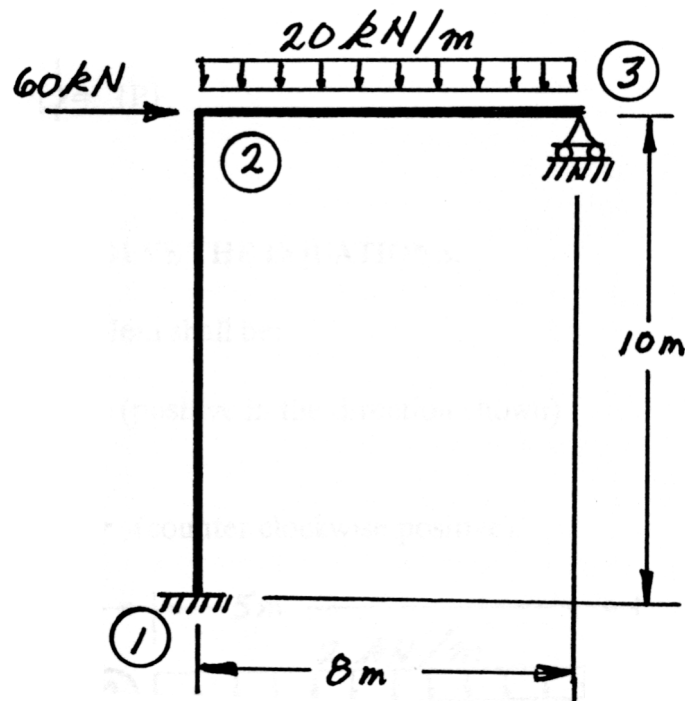

SELECT AND ANSWER TWO QUESTIONS ONLY FORM QUESTIONS 6, 7, 8 OR 9.

- (22) 9. a) For the frame shown, derive the equilibrium equation for translation δ at joint 2. Neglect the effects of axial strain. EI has the same value for all members.
- b) Derive the equilibrium equations for moment equilibrium at joints 2 and 3.
- c) Present your results in matrix form by giving the terms of the stiffness matrix $[K]$ and the load vector $\{P\}$ in the following equation:

$$[K] \begin{Bmatrix} \delta \\ \theta_2 \\ \theta_3 \end{Bmatrix} = \{P\}$$

DO NOT SOLVE THE EQUATIONS.

The unknowns of the problem shall be:

δ = translation at joint 2 (positive in the direction shown)

θ_2 = rotation of joint 2
 θ_3 = rotation of joint 3 } (counter clockwise positive)

