

**THE ASSOCIATION OF PROFESSIONAL ENGINEERS**  
**98-MEC-B1 ADVANCED MACHINE DESIGN**  
**NATIONAL COURSE EXAMINATION**

**December 2002**

**TIME ALLOWED: 3:00 (three) Hours**

---

**Please Note:**

- ◆ Answer QUESTION NUMBER-1, and only TWO questions from PART-II of the examination.
- ◆ Make your answer neat, write your equations in symbol form first and put intermediate and final results in boxes.
- ◆ Examination is open book (one book only). Students may use only one textbook of their choice plus their own notes.
- ◆ Any non-communicating calculator is permitted.
- ◆ State all assumptions clearly. If doubt exists as to the interpretation of any question, submit with the answer paper a clear statement of any assumptions or interpretation made.
- ◆ Assume any missing data and make sure to properly state it in your answer.
- ◆ Make sure your name and student number (if applicable) is written on the answer book and any other attachments.
- ◆ Total points of the examination are 100 marks.

**PART- I: ONLY QUESTION-1 – MUST BE SOLVED**

**QUESTION-1: DESIGN OF A MOBILE CRANE**

**(50 points)**

Figure-1 shows a sketch of mobile crane with dimensions in meters as shown in the figure. Two identical hydraulic cylinders, one on each side of the crane boom, are used to lift a maximum of 5 tones (5,000 kgs) at the pulley end D of the boom. Points A, B and C are all hinged connection with assumed no friction. The following data is available for the designer:

- The extending boom of the crane is to be designed for a maximum extension of 16 meters.
- The hydraulic cylinders have a maximum extension of 4.2 meters.
- The internal diameter of the hydraulic cylinder is (0.15 m) 15 cm.
- Material of the cylinder, piston rod and all pins in the assembly is SAE-1040 with:
 

$S_y$ : material yield strength	$S_u$ : material ultimate strength
= 450 MPa	= 650 MPa
- A factor of safety of 1.75 is to be used in all calculations.
- The minimum extension of the hydraulic cylinder occurs when the boom DEAC is horizontal.

**It is required to:**

- (a) Find the maximum force transmitted by each hydraulic cylinder and the required internal pressure.
- (b) Find the minimum thickness of the cylinder wall.
- (c) Find the diameter of the piston rod of the hydraulic cylinder.
- (d) Design a suitable pin at point C (suggest a material and find pin diameter)
- (e) Write down the equations required to calculate the maximum vertical deflection at point D. Do not solve for the deflection value. The following data may be used:  
 Boom DE: Length =  $L_1$ , Section moment of inertia =  $I_1$  and cross sectional area =  $A_1$   
 Boom DC: Length =  $L_2$ , Section moment of inertia =  $I_2$  and cross sectional area =  $A_2$
- (f) Make a free hand (you may use a straight edge) engineering drawing for:
  - The piston and piston rod connection in the hydraulic cylinder.
  - The pulley and pin assembly at point-D at the end of the boom.

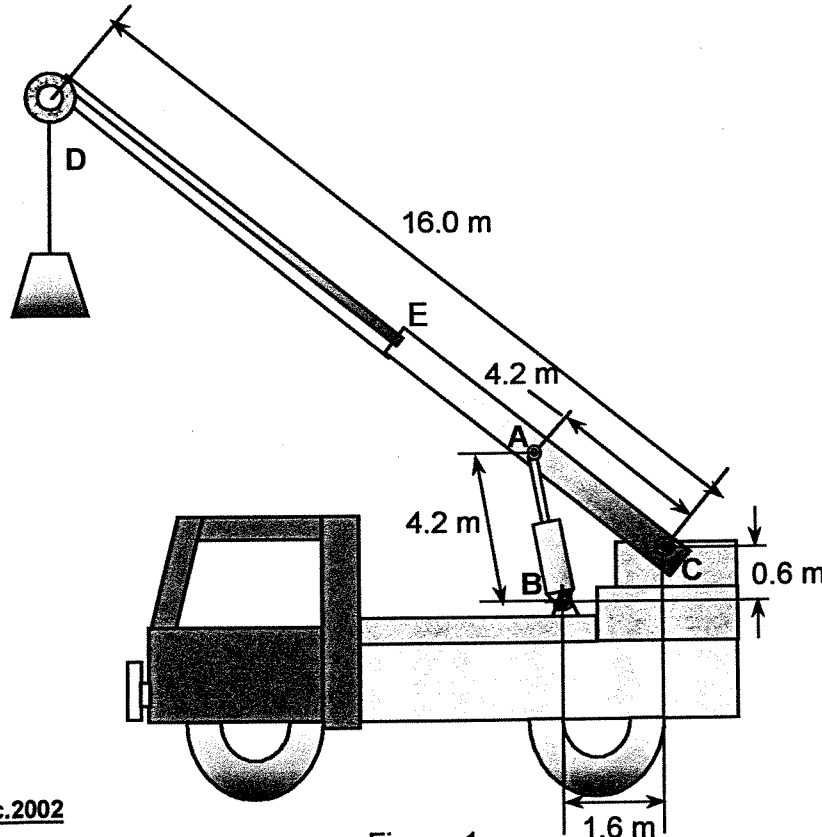

Figure-1

**PART- II: QUESTIONS 2, 3 AND 4 - ONLY SOLVE TWO QUESTION FROM THIS PART**

**QUESTION-2: Brake Design**

**(25 points)**

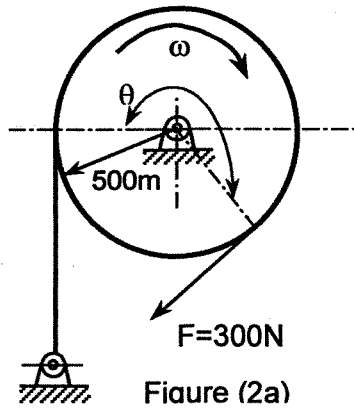
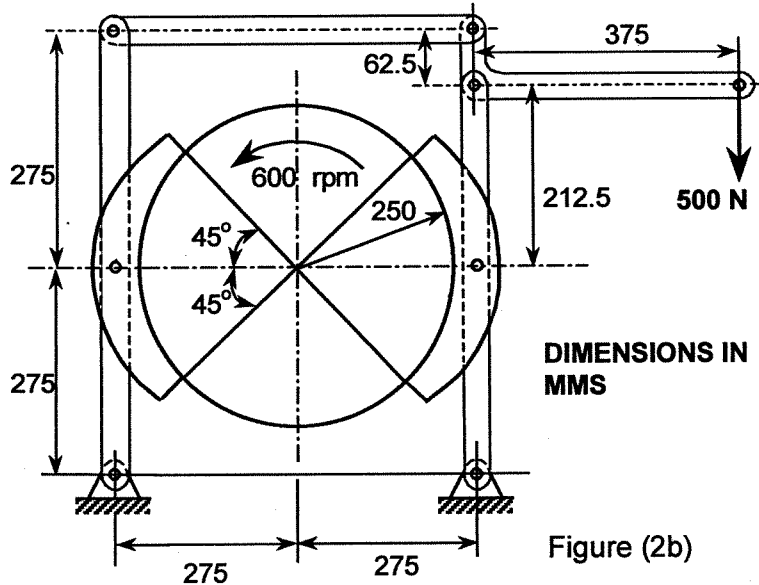

Figure (2a)



DIMENSIONS IN MMS

Figure (2b)

(a) Figure (2a) shows a simple band brake operated by an air cylinder that applies a force  $F$  of 300 N as shown. The drum radius is 500 mm. The band is 30 mm wide and has a coefficient of friction of 0.45. What is the angle of wrap  $\theta$  that will be necessary to obtain a brake torque of 800 N.m.? What is the corresponding maximum lining pressure?

(b) Figure (2b) shows a double-block brake with its drum rotating counter-clockwise at 600 rpm and an actuating force of 500 N acting vertically downward as shown in the figure. The brake has a face width of 100 mm and a mean coefficient of friction of 0.2. Draw a free-body diagram for all parts (links) of the brake and calculate all forces on each part and find the value of the maximum pressure for each shoe, the torque exerted by the brake and the absorbed power.

**QUESTION-3: DESIGN OF JOURNAL BEARING**

**(25 points)**

It is required to design a journal bearing for use in a production line conveyor transporting industrial raw material. The vertical bearing load is 500 pounds downward, and the journal is to rotate at a constant speed of 600 rpm. High load carrying capacity is regarded as more important than low friction loss in the bearing.

- (i) Determine a proper combination of dimensions, lubricant parameters and average oil temperature suitable for the proposed application.
- (ii) Plot  $f$  (coefficient of friction),  $h_o$  (minimum film thickness),  $\Delta T$  (temperature rise), and  $Q$  (the oil flow rate) for a range of radial clearances. From the plot, suggest an appropriate range of production clearance and reason your choice

**QUESTION-4:**

**(25 points)**

A mass of 1500 kgs is suspended from a bent-supporting member as shown in Figure-4. This is being carried on a moving platform that is accelerated at a rate of  $5 \text{ m/sec}^2$  in the lateral direction (perpendicular to the plane of the bent member). The member cross-section is a thin-walled I-beam with the shown dimensions and properties. In terms of the thickness,  $t$ , find all stress components at this point. Identify a possible critical point on the section and find the maximum principal stresses if the section is considered to be a straight beam? (NB: neglect the inertia of the bent member and only consider the inertia of the concentrated mass).

**GIVEN DATA:**  
 Mass,  $M = 1500 \text{ Kgs}$   
 Acceleration,  $a = 5 \text{ m/sec}^2$   
 Radius,  $R = 60 t$   
 $I_{xx} = 170 t^4$     $I_{yy} = 1350 t^4$   
 Area,  $A = 34 t^2$

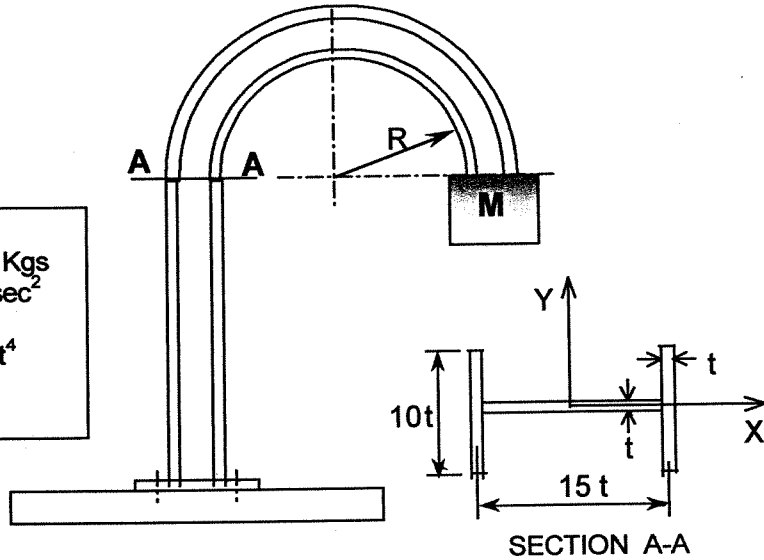

Figure-P4

