

National Examinations - May 2002

98-Mec-A5: Design and Manufacture of Machine Elements

3 Hours Duration

Notes:

If doubt exists as to the interpretation of any question, the candidate is urged to submit a clear statement of any assumptions made, with the answer paper.

2. Any non-communicating calculator is permitted. Write the name and model designation of the calculator on the first inside sheet of the exam work book.
3. This is an open book examination.
4. There are 7 questions on the following 3 pages.
5. Any 5 (five) questions constitute a complete paper. Only the first five questions, as they appear in your answer book, will be marked.
6. All questions are of equal mark value (20%). Candidates are cautioned that the problems are not equally long, nor are they of equal difficulty.

1. A steel plate is welded to a column with E6010 electrode, as shown in Figure 1. The steady load, $F = 50.0 \text{ kN}$, is applied such that no twisting of the plate will occur. Welds AB and CD are each 10 mm fillet welds.

Find:

- a) the magnitude of the maximum shear stress produced in the welds. Clearly indicate its location.
- b) the factor of safety in the welds.

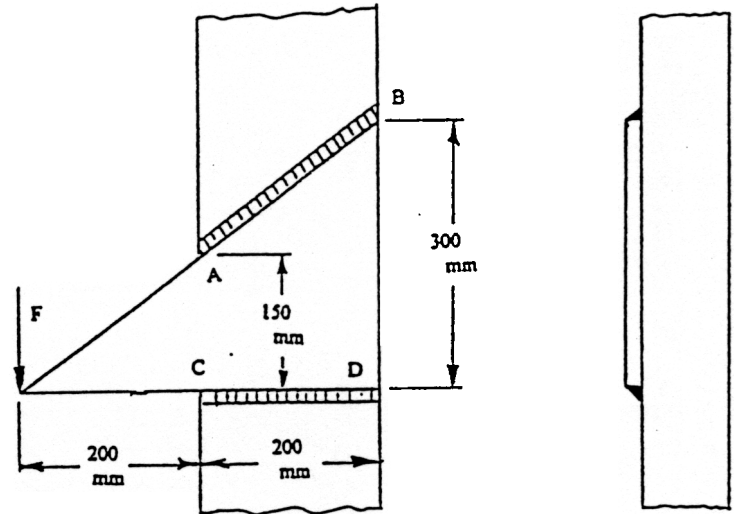

Figure 1

2. a) Discuss the function(s) of the fibres, and of the matrix, in a composite material. Sketch a cylindrical pressure vessel made from composite material, and indicate the directions of the fibres.
- b) Plastic brake and clutch pedal arms are being introduced into production for many current model year cars. Those pedals with left or right offsets at the pedals (bent near the bottom ends, to clear the steering column, wheel wells, etc.), experience both bending and torsion near the pivot points at their upper ends. Choose a low cost composite plastic material for these arms, and sketch the cross-sections of the arm near the pedal (bottom), and near the pivot point (top). Why did you choose these shapes? Remember that they must be relatively easy to mould.
- c) i) Why are automotive designers investigating the use of ceramic coatings on engine pistons?
 ii) What design and material limitations must they consider when choosing one type of ceramic material in this application?
 iii) Would they specify a ceramic material for the engine's connecting rods? The loading reverses rapidly from tension to compression.
3. Select a suitable steel for a solid circular shaft having a 50.0 mm diameter. Shaft loading is such that the maximum bending moment of 800 Nm and maximum torque of 2000 Nm occur at the same location. The loads are static. The factor of safety is 1.5. Use a reliability of 95 %, or infinite life. Loading is low shock, and is gently applied.

4. The T-shaped support assembly in Figure 2 is constructed from solid 50 mm diameter HR AISI 1015 mild steel. Loading is static. Construct Mohr's Circle for the stresses acting on the top of the member at D (neglect stress concentrations due to the support). Then determine the factor of safety based upon:
- maximum principal stress,
 - maximum shear stress,
 - maximum distortion-energy theory.

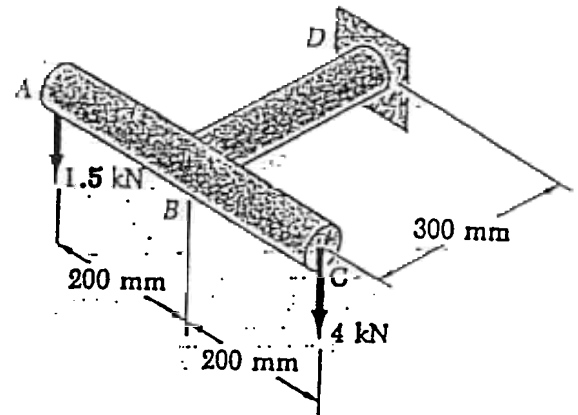

Figure 2

5. a) Briefly discuss the advantages and disadvantages of die-casting the following 4 metals: white metal, zinc, aluminum, magnesium.
- b) Of the many processes available for hot-forming metals, four are: sand casting, die casting, centrifugal casting, and near-net-shape (lost foam) casting. Briefly compare these 4 methods, with respect to:
- | | | |
|--------------------------------------|--------------------------|-------------------|
| - metals cast | - casting size | - production rate |
| - scrap rate | - minimum wall thickness | - cores |
| - other parameters of your choosing. | | |
- c) In comparing gray cast iron to cast steel, the foundry engineer and the design engineer will present quite different viewpoints. Explain why the foundry prefers not to have to cast steels (manufacturing problems), while the designer likes to specify cast steel for many applications (mechanical properties).
6. For a short term project at a remote location, it is required that the ball bearings have 99 % reliability for a lifespan of 3 weeks of continuous running at 500 RPM. The bearings' inner races rotate. For each bearing, the radial load is 1100 N and the thrust load is 325 N.

Select a suitable single row, deep groove ball bearing in the 02 series, which operates under light vibration conditions.

7. Note: Answer part questions totalling 20 marks, in any combination desired.

- a) (8 marks) The chassis of a heavy duty truck is constructed of AISI 1050 (G10500) steel drawn at 600°F (320°C) into a channel (C) shape. Discuss why there are "no welding" stickers attached to the chassis. Using sketches, clearly show how you would mount suspension and body elements to the chassis, without destroying its strength.
- b) (12 marks) The world's steel industry commissioned the design of a prototype automobile body for the car of the near future. The ULSAB (ultra light steel auto body) featured several innovative techniques.
- i) The complex fore-and-aft rails above the doors were formed in one piece by the hydroforming process. Discuss the advantages of using this process in this application. What method(s) would have been used to form this part prior to hydroforming?
 - ii) Many body panels were formed by using "tailored blanks". In this process, dissimilar sheets of steel are laser-welded together. Use the outer panel of a car door as one application, and consider strength, formability and environmental problems. Indicate clearly how you would design a lightweight tailored-blank door panel.
- c) (2 marks for each part) Clearly indicate one preferred method of metal removal in your choice of the following situations, involving steel members:
- i) a low carbon solid circular section transmission shaft, with many steps of varying depth. Suggest a steel for use in this application.
 - ii) the final tooth shape for a hardened steel gear, if a "precision finish" is specified,
 - iii) the complex "teardrop" shape for a through port in the end plate of a hydraulic pump,
 - iv) the teeth on an internal gear (teeth cut on the inside surface of the blank, before hardening),
 - v) the final finish for a needle roller bearing surface on a 1050 (G10500) CD shaft,
 - vi) the through keyway on the inside surface of a gear hub,
 - vii) reducing the thickness of a 100 mm by 500 mm flat mild steel plate from 25 mm to 21.5 ± 0.1 mm thickness.