

DEC 2003

NATIONAL EXAMINATIONS

98-BS-11 Properties of Materials

3 Hours Duration

**Notes:**

- (i) If doubt exists as to the interpretation of any question, the candidate is urged to submit with the answer paper, a clear statement of any assumption made.
- (ii) Candidates may use one of two calculators, the Casio or Sharp approved models. This is a "closed book" examination.
- (iii) Any five questions constitute a complete paper. Only the first five questions as they appear in your answer book will be marked.
- (iv) All questions are of equal value.

**Information:**

(1) Atomic Masses (g.mol<sup>-1</sup>)

H	1.01	C	12.01	N	14.01	O	16.00	Na	22.99
Si	28.08	Cu	63.54						

(2) Constants and Conversions

Avagadro's number,  $N_A = 6.02 \times 10^{23} \text{ mol}^{-1}$

Boltzmann's constant,  $k = 1.38 \times 10^{-23} \text{ J.K}^{-1}$

Universal gas constant,  $R = 8.314 \text{ J. mol}^{-1} .\text{K}^{-1}$

(3) Prefixes

tera	T	$10^{12}$	milli	m	$10^{-3}$
giga	G	$10^9$	micro	$\mu$	$10^{-6}$
mega	M	$10^6$	nano	n	$10^{-9}$
kilo	k	$10^3$	pico	p	$10^{-12}$

**Questions:**

1. (a) Determine the Miller indices for the planes A and B shown at the right.
- (b) Determine the lattice constant  $a_0$  for copper, given that its density is  $8.93 \text{ g.cm}^{-3}$ .
- (c) It is desired to have 10,000 times as many vacancies as the number present at room temperature in pure copper. Design a heat treatment process (calculate any temperatures needed). Use  $83.7 \text{ kJ/mol}$  as the energy of vacancy formation in copper.

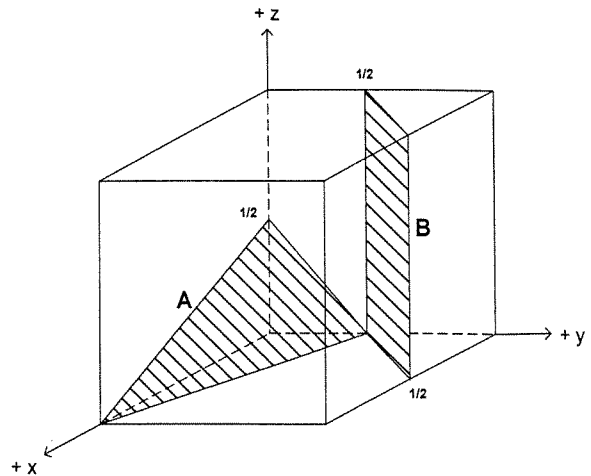

2. (a) In a tensile test an extensometer is used to obtain accurate values for the sample gauge length  $l$ . Show that the true strain  $\epsilon_T$  is given by:

$$\epsilon_T = \ln\left(\frac{l}{l_0}\right) \quad \dots\dots (1)$$

The true strain can also be determined by monitoring the diameter  $d$ . Show that if the specimen volume remains constant the true strain is given by:

$$\epsilon_T = 2 \ln\left(\frac{d_0}{d}\right) \quad \dots\dots (2)$$

Which of the two expressions is more valid during necking? Why? ( $l_0$  and  $d_0$  are the initial sample gauge length and diameter, respectively).

- (b) Describe the Brinell hardness test. This hardness test gives a closer correlation to tensile strength of structural steels than other hardness tests. Explain. Why does this correlation not exist for heat treated steels?
3. (a) A 1.35 kg brick consists of 85% sand ( $\text{SiO}_2$ ) and 15% sodium metasilicate ( $\text{Na}_2\text{SiO}_3 \cdot 9\text{H}_2\text{O}$ ). Sodium metasilicate is known to lose  $6\text{H}_2\text{O}$  at  $100^\circ\text{C}$ . What will be the mass of the brick after heating at a temperature slightly above  $100^\circ\text{C}$ ?
  - (b) Canadian steelmakers have introduced "concasters" as an alternative to ingot casting. Discuss the principal advantages of using continuous casting. Mention also any disadvantages.

4. (a) A tank is made of low alloy steel with a yield strength 600 MPa and plane strain fracture toughness  $120 \text{ MPa}\cdot\text{m}^{1/2}$ . The steel is exposed to a stress not exceeding 70% of the yield strength. Calculate the minimum size of crack to cause failure. What methods are available to detect cracks of this size?
- (b) Explain why statistical methods are often used to predict failure in ceramic materials. In particular, discuss how the Weibull distribution is employed.
- (c) Discuss some methods that are employed to improve the fracture toughness of ceramic materials.
5. (a) Analysis of a sample of polyacrylonitrile  $(\text{CH}_2\text{-CH}\cdot\text{CN})_n$  gives the following data for six chain length groups:

<u>Number of chains</u>	<u>Mean molecular weight of chains (g/mol)</u>
10,000	3,000
18,000	6,000
17,000	9,000
15,000	12,000
9,000	15,000
4,000	18,000

Determine the weight average and number average molecular weights for this polymer. Based on the weight average molecular weight find the degree of polymerization.

- (b) A stress of 4000 psi is applied to a polymer serving as a fastener in a complex assembly. At a constant strain, the stress drops to 3500 psi after 100 hours. If the stress on the fastener must remain above 2500 psi in order for the part to function properly, determine the life of the assembly.
6. (a) It is possible to purify a metal by using the knowledge that the composition of the first solid to form is not the same as the composition of the liquid from which it first forms. The method is known as "zone refining". Use a phase diagram to explain how this might work.
- (b) Show that the minimum ionic ratio for 6-fold coordination is 0.414.

7.

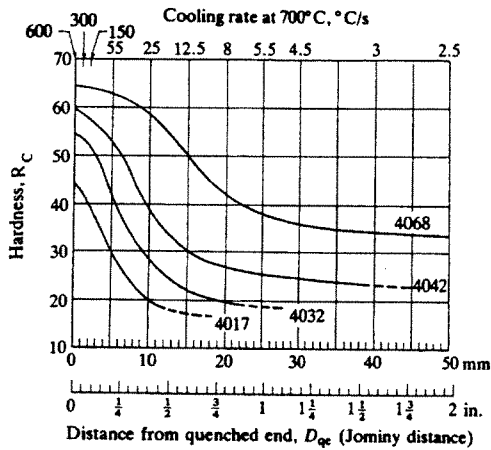

Hardenability Curves for AISI-SAE 40xx Steels.

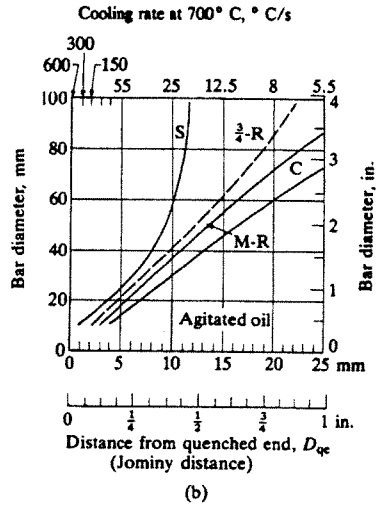
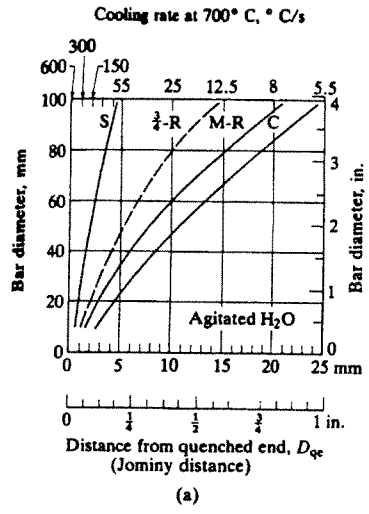

Cooling rates in round steel bars (a) quenched in agitated water, and (b) agitated oil

- (a) A 60 mm diameter steel bar made of SAE 4017 steel has been carburized to 0.68% C at the surface, to 0.42% C at 3 mm below the surface, and remains at 0.17% C at 7.5 mm below the surface. Determine the hardness profile of the steel bar after oil quenching.
- (b) Using appropriate sketches discuss martempering and austempering. Why are they done and what are the limitations of each process?

8. (a) One end of a copper wire is immersed in an electrolyte of  $0.03\text{ M Cu}^{2+}$  ions and the other in one of  $0.002\text{ M Cu}^{2+}$  ions, with the two electrolytes being separated by a porous wall.

- (i) Which end of the wire will corrode?
- (ii) What will be the potential difference between the two ends of the wire when it is first immersed in the electrolytes?

The standard electrode potential  $E^\circ$  for copper ( $\text{Cu} \rightarrow \text{Cu}^{2+} + 2e^-$ ) is  $+0.34$  Volts.

(b) Cartridge brass CA260 (70Cu30Zn) is one of the most formable engineering alloys, making it ideal for deep drawing applications. Unfortunately, it is prone to corrosion due to "season cracking" (stress corrosion cracking) and "dezincification" (selective leaching). Describe these two types of corrosion and indicate how they can be minimized.