

**Professional Engineers
Ontario**

May 2004

**National Exams
98-Civ-B9**

Applications of the Finite Element Method

Notes:

- There are 4 pages in this exam paper.
 - This is a closed book exam.
 - If doubt exists as to the interpretation of any question, the candidate is urged to submit, with the answer paper, a clear statement of any assumptions made.
 - Candidates may use one of the approved Casio or Sharp calculators.
 - All parts are of equal value.
 - Answer only **two** parts out of the three presented.
-

Part 1: (You have to answer questions 1. through 10. if you select this part)

1. The solution of an elasticity problem obtained by the Finite Element Method does not verify equilibrium within the domain, explain why?
2. How is it possible to estimate the error of the results from a finite element stress analysis?
3. Select the right answer to the following statement:
The strain energy of an elastic structure calculated by the finite element method is:
 - a) higher than the exact value
 - b) equal to the exact value
 - c) lower than the exact value

4. Draw the approximate shape functions for the two truss elements shown in the following figure.



5. What does the term “hybrid finite element” mean?
6. What does the term “reduced integration” mean?
7. What is the difference between “Euler-Bernoulli” and “Timoshenko” beam elements? When do you use each one of them?
8. Why are linear quadrilateral elements not good candidates for flexural dominant problems?
9. What does the term “ C^1 plate element” mean?
10. What assumptions would be made to analyse a large concrete gravity dam subjected seismic loads?

Part 2

The beam shown in Figure 2 has uniform stiffness EI . Starting with the trial function $v = a_0 + a_1x + a_2x^2$ for lateral displacement, make the function admissible, then use the Rayleigh-Ritz method to calculate the deflection at $x=L$ and the largest bending moment. What is the percentage error associated with each result?

Note: The exact deflection at $x=L$ is $v = -\frac{PL^3}{3EI}$

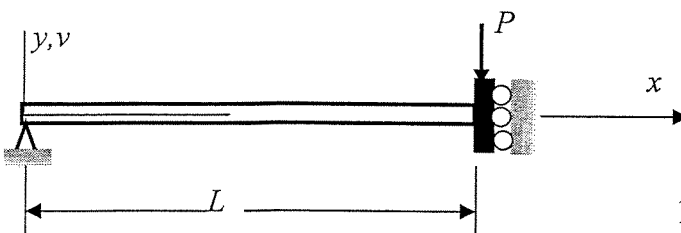

Figure 2

Part 3

Figure 3 shows a plate of thickness t reinforced at the upper and lower edges by two bars with constant cross section A . The plate and the bar are made from the same material which has an elastic modulus equal to E . Applied forces P and $2P$ are also illustrated in the figure.

The plate is modeled using 8 linear triangular elements (Constant Strain Triangle), and each bar is modeled using two truss elements. Assuming that $\left(t = \frac{2A}{L}\right)$,

1. Calculate the horizontal displacements u at nodes 2 and 3.
2. Calculate ε_x and ε_y at any point C within the triangle shown in the figure.

Clearly state and justify all assumptions in your solution and show all steps used in the finite element procedures.

Note: The stiffness matrix of a typical CST element is given in the next page.

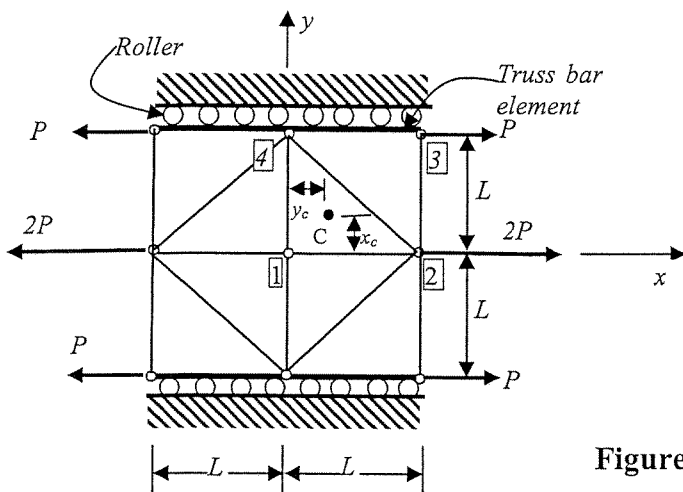

$$E = 200 \text{ GPa}$$

$$\nu = 0.2$$

$$t = 5 \text{ mm}$$

$$L = 20 \text{ mm}$$

$$P = 5 \text{ kN}$$

Figure 3

Stiffness matrix a CST element (6 dof)

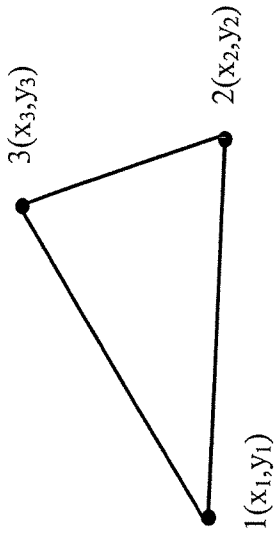

$$\left[\begin{array}{cccccc} \frac{H_1^2 y_{23}^2 + Gx_{32}^2}{4A} & H_2 x_{32} y_{23} + Gx_{32} y_{23} & H_1 y_{31} y_{23} + Gx_{32} x_{13} & H_2 x_{13} y_{23} + Gx_{32} y_{31} & H_1 y_{12} y_{23} + Gx_{21} x_{32} & H_2 x_{21} y_{23} + Gx_{32} y_{12} \\ H_1 x_{32}^2 + Gy_{23}^2 & H_2 x_{32} y_{31} + Gx_{13} y_{23} & H_2 x_{32} x_{13} + Gy_{31} y_{23} & H_1 x_{32} x_{13} + Gy_{31} y_{23} & H_2 x_{32} y_{12} + Gx_{21} y_{23} & H_1 x_{32} x_{21} + Gy_{12} y_{23} \\ H_1 y_{31}^2 + Gx_{13}^2 & H_1 y_{31}^2 + Gx_{13}^2 & H_2 x_{13} y_{31} + Gx_{13} y_{31} & H_1 y_{12} y_{31} + Gx_{13} x_{21} & H_2 x_{21} y_{31} + Gx_{13} y_{31} & H_1 x_{13} x_{21} + Gy_{12} y_{31} \\ \text{Symmetry} & \text{Symmetry} & \text{Symmetry} & \text{Symmetry} & \text{Symmetry} & \text{Symmetry} \end{array} \right]$$

$$H_1 = \frac{2G(1-av)}{(1-v-av)}, \quad H_2 = \frac{vH_1}{1-av}, \quad G = \frac{E}{2(1+v)}, \quad x_{ij} = x_i - x_j, \quad y_{ij} = y_i - y_j$$

$a=0$ plane stress, $a=1$ plane strain
 A is the area of the triangle
 t is the thickness of the triangle