

Front Page

National Exams December 2008

04-Chem-B6 - Petroleum Refining and Petrochemicals

3 hours duration

NOTES

- 1 If doubt exists as to the interpretation of any question the candidate is urged to submit with the answer paper, a clear statement of any assumptions made
- 2 This is a CLOSED BOOK EXAM
calculator is permitted
- 3 FIVE (5) problems constitute a complete exam paper
The first five problems as they appear in the answer book will be marked
- 4 Each problem is of equal value
- 5 Note that the questions (a) (b) (c) (d) (e) (f) or (g) of each problem can be treated independently
- 6 Most questions require an answer in essay format. Clarity and organization of the answer are important. Some of the questions require calculations please show all your steps

Problem 1 (20 marks)

- (a) Explain why the specific gravity of crude oil alone is not sufficient to classify all oils?
3
- (b) What would be a more accurate way to classify crude oils?
3
- (c) Explain briefly why crude oils need to be refined before using them as fuels
4
- (d) A gas containing 80% ethane (C_2H_6) and 20% O_2 is burned with 200% excess air in one of the dedicated boilers of a modern refinery. 80% of the ethane goes to CO_2 , 10% goes to CO and 10% remains unburned. Calculate the composition of the flue gases at the stack.
10

Problem 2 (20 marks)

- (a) Explain the main mode of characterization of petroleum fractions?
3
- (i) What are their advantages?
2
- (ii) What are their limitations?
2
- (b) Explain very concisely the importance of isomerisation in the petroleum refining operation
3
- (c) A distillation column in a petroleum refinery is shown in the diagram below with all known information on the feed and distillate. Calculate the amount of alcohol lost in the bottoms.
10

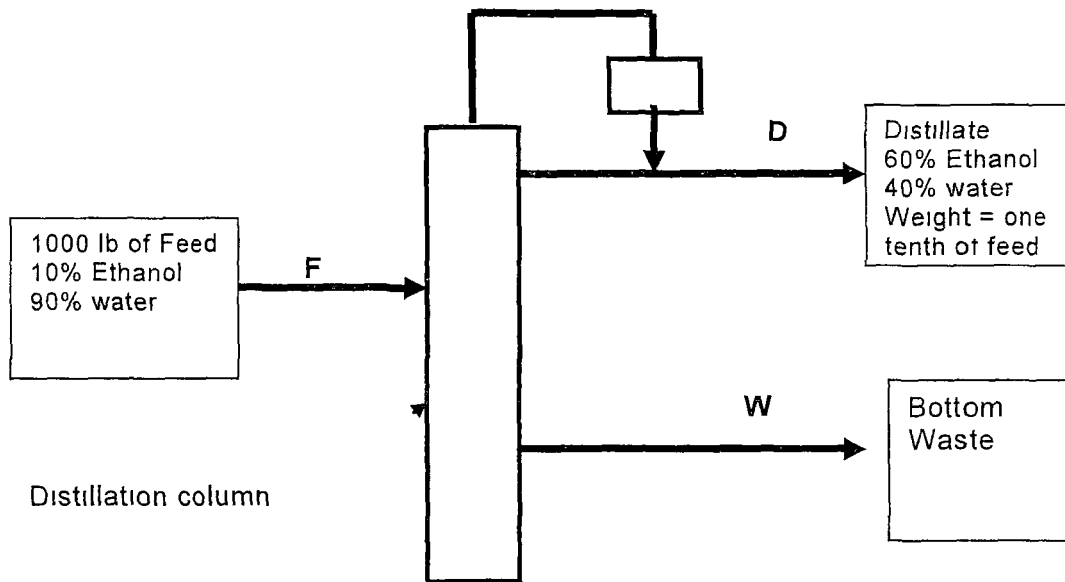

Problem 3 (20 marks)

- (a) Explain briefly the impact of the following process variables on catalytic reforming temperature pressure hydrogen to oil ratio, water content and space velocity

5

- (b) Most catalysts used during catalytic reforming processes lose gradually their activity Explain what causes this deactivation process and why it occurs?

3

- (c) To separate crude oil into its different fractions distillation may be used Explain how and why this separation method works for crude oils

4

- (d) If you have a 15 lb of carbon dioxide in a 30 ft³ tank at 35 C What will the pressure gauge on the tank read? Hint assume carbon dioxide to be an ideal gas

8

Problem 4 (20 marks)

- (a) Explain briefly what is alkylation for the petroleum industry?
3
- (b) What is the impact of contact time, reactor temperature and catalyst activity on the alkylation reaction?
3
- (c) List four important design or operating factors that need to be taken into consideration in the design of reactors for hydrocrackers?
4
- (d) Explain why these design factors are important
2
- (e) What is polymerisation in the petroleum industry?
2
- (f) Explain briefly the main characteristics of thermal polymerization sulphuric acid polymerization and phosphoric acid polymerization
6

Problem 5 (20 marks)

- (a) Explain the process of coking in simple terms
2
- (b) What is it used for and why?
2
- (c) There are two major coking processes delayed coking and fluid coking Explained in a very concise manner
(i) The main characteristics of these two coking processes
4
(ii) And how these two processes differ
2
- (d) A distillation column separates 10 000 lb/hr of a mixture containing 50% benzene and 50% toluene The product recovered from the condenser at the top of the column contains 95% benzene, and the bottom waste from the column contains 96% toluene The stream entering the condenser from the top of the column is 8000 lbs/h A portion of the product is returned to the column as reflux and the rest is withdrawn for downstream application Assume the compositions of the streams at the top of the column (V) the product withdrawn (D) and the reflux (R) are identical Determine the ratio of the amount refluxed to the product withdrawn
10

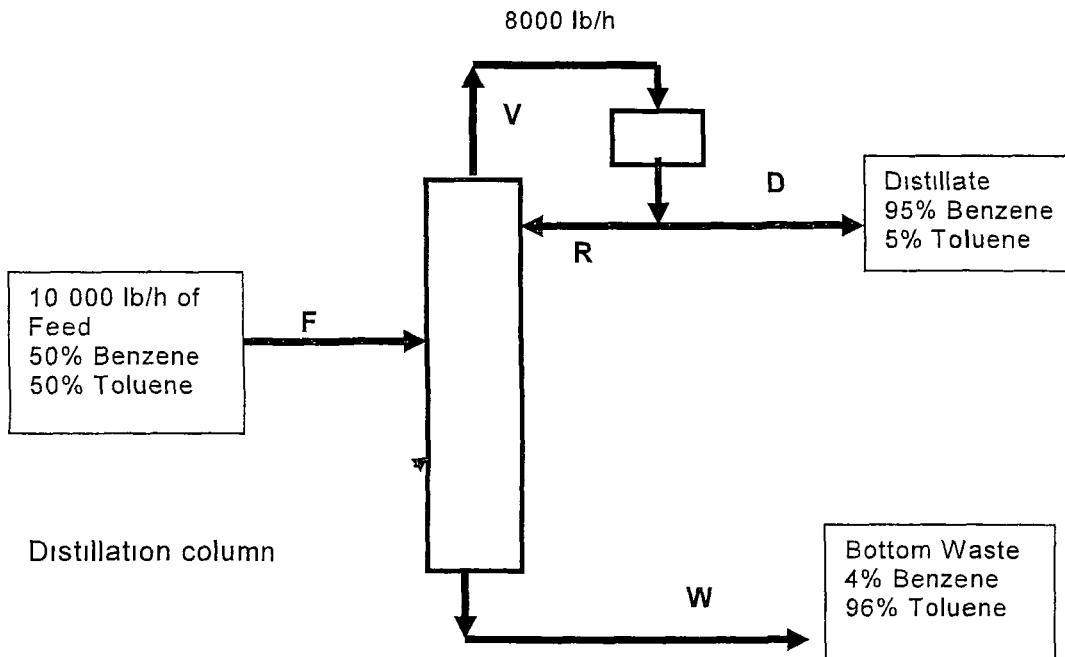

Problem 6 (20 marks)

- (a) Explain how petroleum fuels are rated?
2
- (b) There are two standard test procedures in common use for rating fuels in car the Modified Uniontown procedure and the Modified Borderline Knock procedure Explain briefly how these two methods work
4
- (c) Explain graphically why petroleum greases are considered to be plastic non-Newtonian Hint Viscosity curve
2
- (d) List four of the physical and physico-chemical properties of lubricating oils
4
- (e) Describe in a clear and concise manner three distinct methods used to produce ethylene
3
- (f) Describe two processes that are used to produce aromatics
2
- (g) List three factors that determine the relative economics of these processes used for the production of aromatics
3