

PROFESSIONAL ENGINEERS ONTARIO
National Examinations - December 2008
07-Mec-A5, Electrical & Electronics Engineering
Mechanical Engineering

3 hours duration

Name [print]

Signature

Notes

- [1] If doubt exists as to the interpretation of any question, the candidate is urged to submit, with the answer paper, a clear statement of any assumptions made
- [2] Candidates may use one of two calculators, the Casio or Sharp approved models. This is a closed book examination.
- [3] Any five questions constitute a complete paper. Only the first five questions as they appear in your answer book will be marked.
- [4] Each question is of equal value.
- [5] Clarity and organization are important.
- [6] The candidate is required to sign this examination paper and submit it with the solution booklets.
- [7] $\pi = 3.14159$
 $1 \text{ hp} = 746 \text{ W}$
 $\mu_0 = 4\pi \times 10^{-7} \text{ H m}^{-1}$

Front Page

QUESTION 1

Consider the transistor circuit shown in Figure 1. All transistors can be assumed to be identical with a dc current gain β .

Calculate the current transfer ratio for the circuit, I_2 / I_1 , as a function of β .

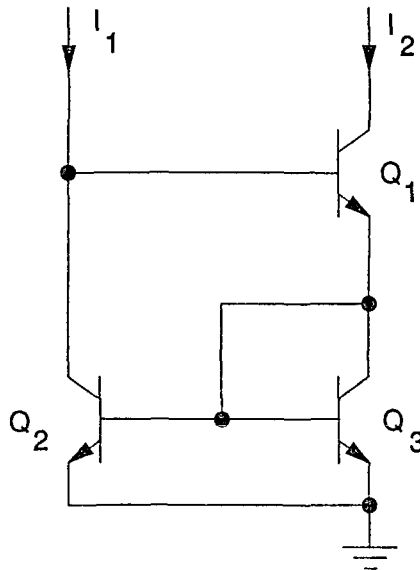

Figure 1 Transistor Circuit

QUESTION 2

Consider the circuit shown in Figure 2 which has been designed using ideal operational amplifiers (U_1 to U_3) with infinite bandwidth and infinite open loop gain. In the schematic, a , b and c are constants. You will note that U_3 is configured as a basic difference amplifier, which has a transfer function given by

$$E_o = c (e_y - e_x)$$

where e_y and e_x are the potentials at points y and x respectively

In the derivation of the transfer function for such circuits, one can assume

- [i] Zero differential voltage between the input terminals of the operational amplifier,
- [ii] Zero current flows into either terminal of the operational amplifier

Applying the principle of superposition, derive an expression for the transfer function of the total circuit [E_o as a function of E_1 , E_2]

Hint Let $E_2 = 0$, and solve for the potentials at points x and y for input E_1
 Let $E_1 = 0$, and again solve for the potentials at points x and y for input E_2
 Calculate the resultant output E_o for both E_1 and E_2 inputs

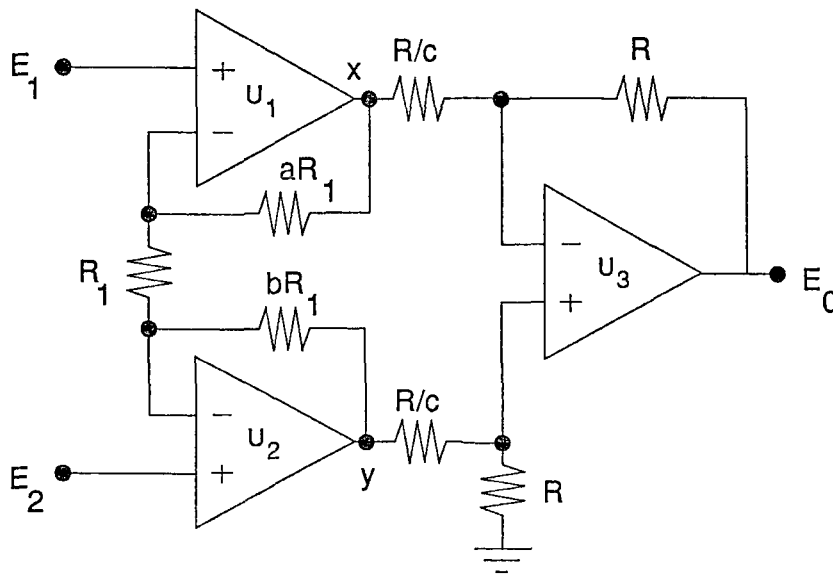

Figure 2 Circuit Schematic

QUESTION 3

Consider the magnetic circuit of a transformer shown in Figure 3. Infinite relative permeability can be assumed for the iron core.

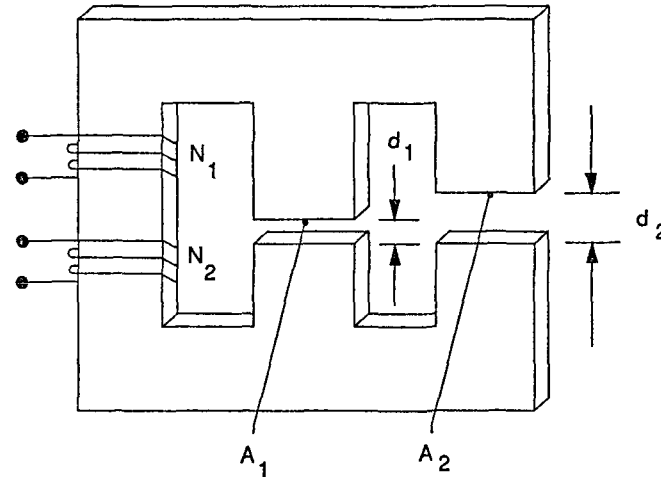

Figure 3 Transformer

The following specifications apply

L_1	$3.77 \times 10^{-2} \text{ m}$	A_1	0.02 m^2
L_2	$7.54 \times 10^{-2} \text{ m}$	A_2	0.02 m^2
N_1 [primary]	200 turns	N_2 [secondary]	20 turns

When a dc voltage equal to 10 mV is applied to the primary, the measured primary current is 100 mA. When a dc voltage of 0.1 mV is applied to the secondary winding, the measured secondary current is 100 mA.

Assume that leakage inductances and eddy current and hysteresis losses are negligible, consider an operating frequency of 1000 Hz.

- Draw the equivalent circuit of the transformer, referred to the primary and calculate component values.
- A transducer, with an impedance of 0.078Ω , is connected across the secondary of the transformer, an amplifier is connected to the primary. Calculate the output impedance of the amplifier to give maximum power transfer to the load.

QUESTION 4

This question consists of two parts which are not necessarily related

Part I Design

Develop the truth table for a 2-input exclusive or gate and write the Boolean algebra expression for the output Y as a function of the inputs A,B

You are provided with quantity six 2-input nor gates Design the gate array to implement the 2-input exclusive or function

Part II Analysis

A combinational logic circuit is shown in Figure 4

- Write a general Boolean algebra expression for the output C as a function of the inputs A, B, K_0 , and K_1
- Apply DeMorgan's theorems and simplify the expression obtained in [a]
- For each of the 4 possible combinations of K_0 , K_1 , reduce the expression for C to its simplest form

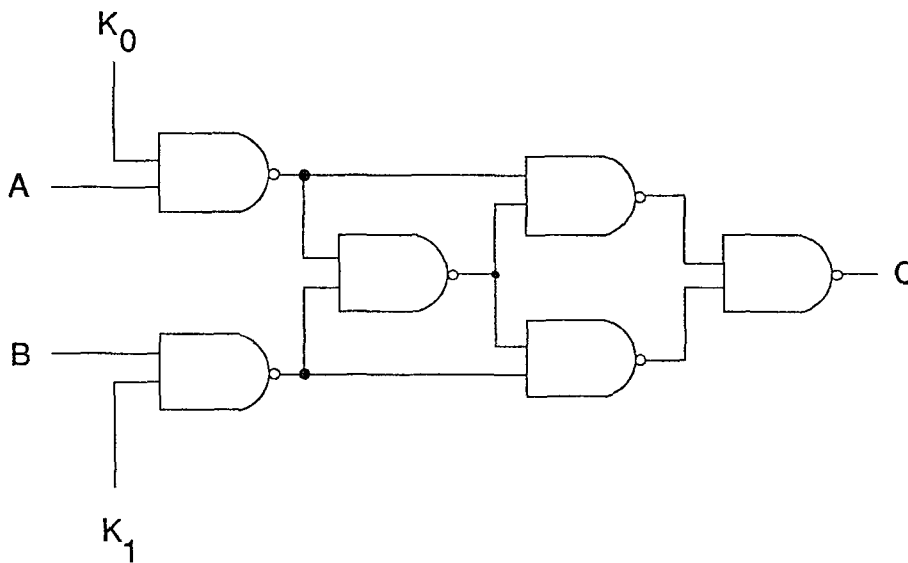

Figure 4 Circuit Schematic

QUESTION 5

The results of no-load and blocked-rotor tests conducted on a three-phase wye-connected induction motor are as follows

No-load test

line-to-line voltage 400V
input power 1770W
input current 18.5A
friction and windage loss 600W

Blocked-rotor test

line-to-line voltage 45V
input power 2700W
input current 63A

- [a] Sketch the equivalent circuit of the induction motor and identify all parameters
- [b] Determine the parameters of the equivalent circuit of the induction motor

QUESTION 6

An industrial load is represented in Figure 6 by $R = 6\Omega$ and $X_L = 8\Omega$. The load voltage is $250\angle 0^\circ$ V.

- Calculate the load current, power, reactive power and power factor.
- Calculate the generator voltage V_G required at the input end of the transmission line (represented by the series impedance $Z_T = (1 + j3)\Omega$) and the power lost in transmission P_T .
- If capacitor $X_C = 12.5\Omega$ is connected in parallel by closing switch S, calculate I_C , the new load current I, and the new power factor. Show V , I_L , I_C , and I on a phasor diagram.
- Calculate the new generator voltage and the new transmission power loss.
- What two advantages do you see for improving the power factor by adding a parallel capacitor?

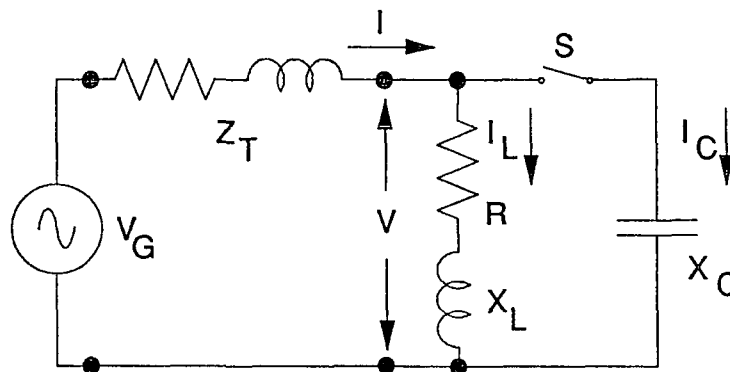

Figure 6 Industrial Load

QUESTION 7

A novel type of dc machine can be designed using a spoke-like rotor with current carrying conductors arranged in a radial fashion as shown in Figure 7. Current is fed radially through the rotor spokes via two ring shaped carbon brushes. The rotor lies in the horizontal plane and is situated in a uniform vertical magnetic field.

The rotor has an outer radius $R_2 = 0.2$ m and an inner radius $R_1 = 0.05$ m and consists of 8 conductors. The magnetic flux density B is 0.5 T.

- [a] If the rotor runs at a speed of $n = 3000$ rpm, find the magnitude of the emf e generated between the brushes.
- [b] If a total current of 500 A flows radially between the brushes, calculate the torque that the rotor will be subjected to and determine the output horsepower of the machine.

HINT As a starting point, consider a small radial element of length dr located at a distance r from the centre of rotation.

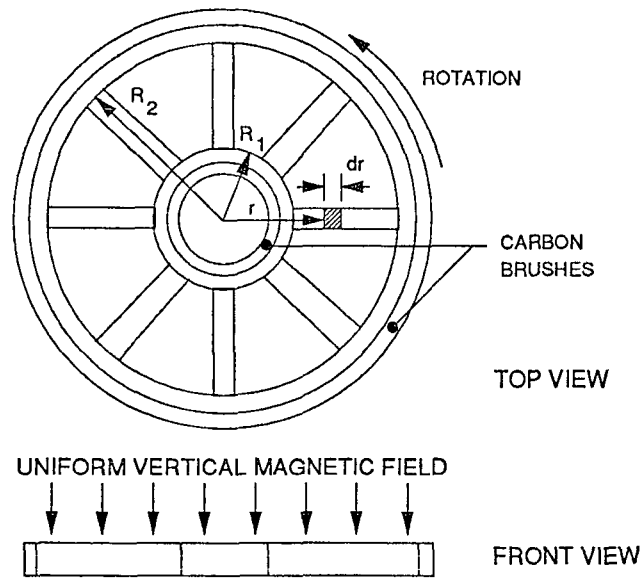

Figure 7 dc Machine

QUESTION 8

Consider the RC circuit shown in Figure 8[a]. The switch S_1 is closed at time $t=0$ connecting the dc supply V_1 to the network

- [a] Derive an expression for the transfer function of the circuit, V_o/V_1 , in the time domain
- [b] Sketch the transfer function for a time interval of 5 time constants

The RC circuit is reconfigured as shown in Figure 8[b]. An ac voltage source of variable frequency v_1 is connected to the input

- [c] Derive an expression for the transfer function of the circuit, v_o/v_1 , in the frequency domain
- [d] Sketch the magnitude of the transfer function for a frequency range of 4 decades centered at the corner frequency of the circuit

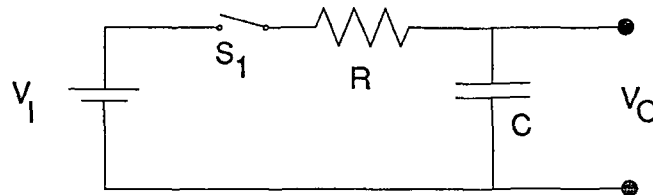

[a]

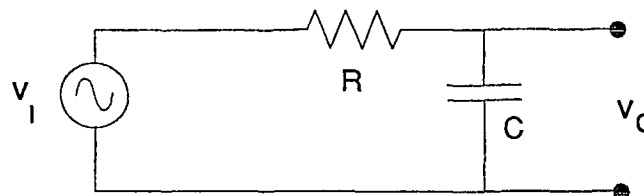

[b]

Figure 8 RC Circuit [a] dc test, [b] ac test