

MAY 2008 NATIONAL EXAMS

98 CIV B1 ADVANCED STRUCTURAL ANALYSIS



3 HOURS DURATION

NOTES

- 1 If doubt exists as to the interpretation of any question the candidate is urged to submit with the answer paper a clear statement of any assumption made
- 2 Each candidate may use an approved model of Sharp or Casio calculator otherwise this is a CLOSED BOOK Examination
- 3 Answer BOTH questions #1 and #2 Answer ONLY TWO of questions #3, #4, or #5 Answer ONLY TWO of questions #6 #7, #8 OR #9 SIX questions constitute a complete paper
- 4 The marks assigned to each question are shown in the left margin

FRONT PAGE

QUESTION #1 MUST BE ANSWERED

- (9) 1 a) Determine the statical indeterminacy, r of the structures shown below
- b) Indicate with arrows ( a rotation  a translation) on each structure and list beside each structure the number of structural degrees of freedom k that are required to do an analysis by the slope deflection method. In each case use the minimum number of structural degrees of freedom. Where they occur, take into account symmetry, anti symmetry and joints that are known to have zero moments

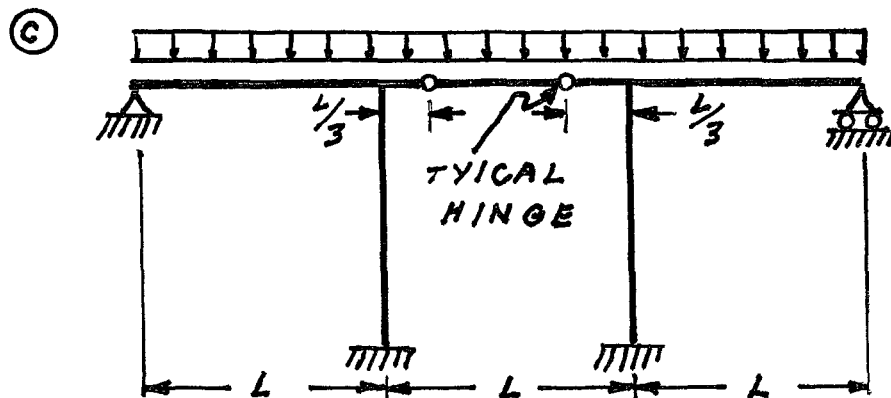
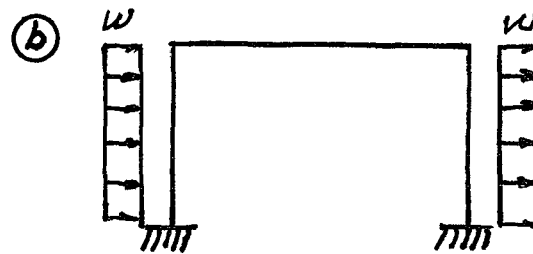
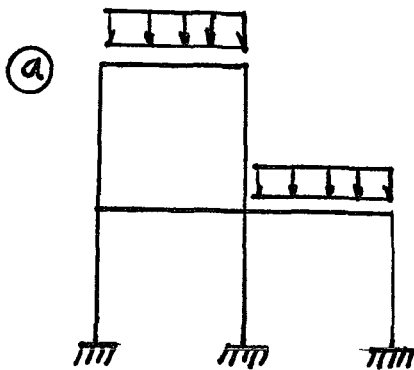

- (11) 2 Schematically show the shear force and bending moment diagrams for the following structures. All members have the same EI and are inextensible.

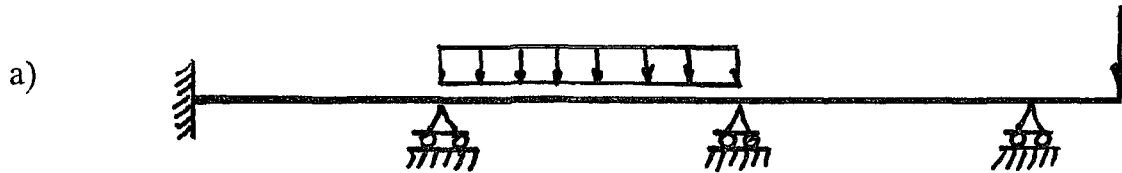

- b) All members decrease in length because of a decrease in temperature.

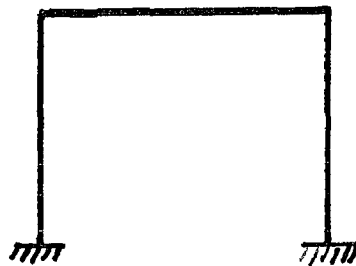

SELECT AND ANSWER TWO QUESTION ONLY FROM QUESTIONS 3, 4, OR 5

- (18) 3 Use Castigliano's theorem to determine the vertical deflection at point C on the beam structure shown. Relative EI values are shown. $EI = 3.0 \times 10^4 \text{ kN m}^2$

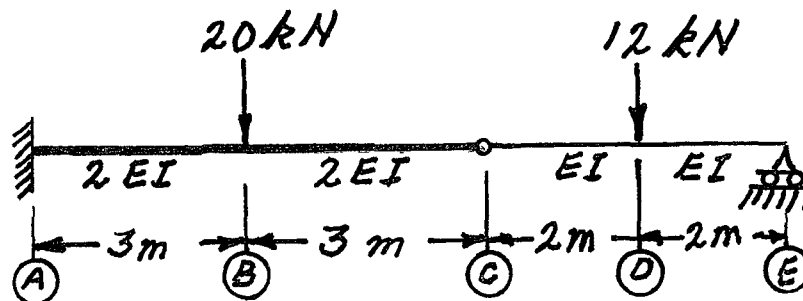

SELECT AND ANSWER TWO QUESTION ONLY FROM QUESTIONS 3, 4, OR 5

- (18) 4 Use Castigliano's theorem (the least work theorem) to analyze the frame shown. Calculate the end and mid span moments for beam ②-③. EI has the same value and is constant along all three members.

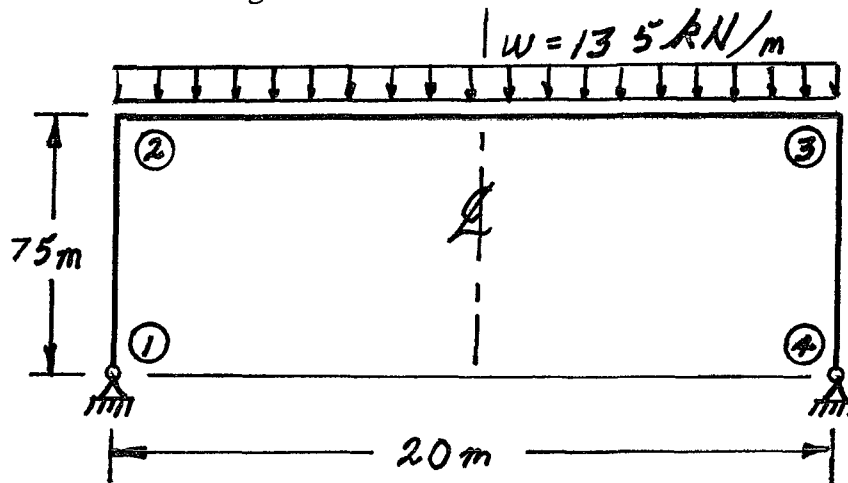

- (18) 5 Use the moment distribution method to analyze the structure shown. Draw shear and bending moment diagrams. On both diagrams for each member label the magnitudes of maximum and minimum ordinates (Minimum ordinates are frequently negative values). All members have the same EI value and are inextensible.

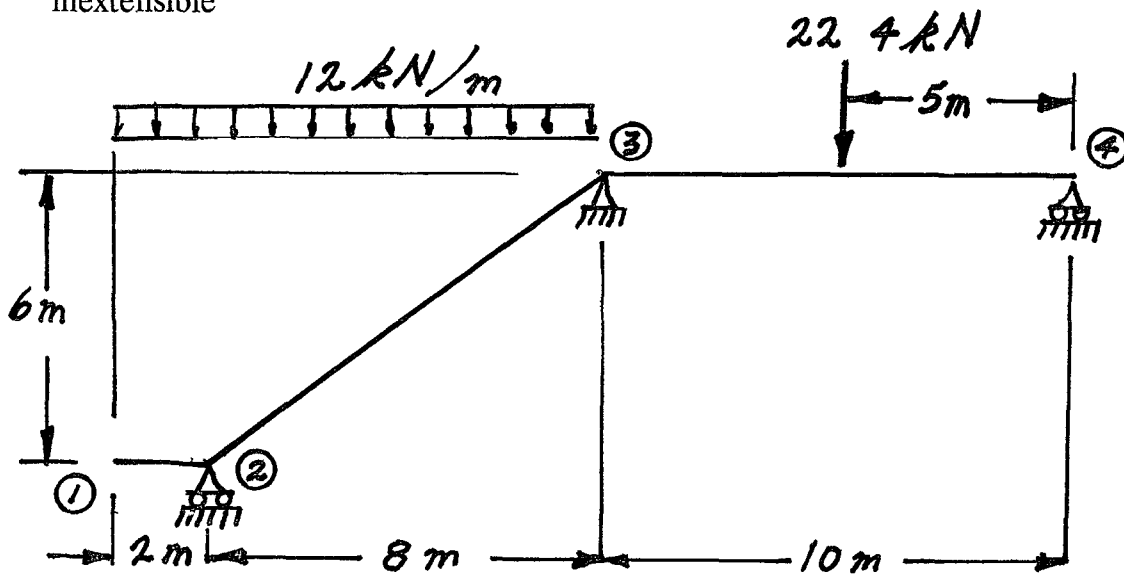

SELECT AND ANSWER TWO QUESTIONS ONLY FROM QUESTIONS 6, 7, 8 OR 9

- (22) 6 Use the slope deflection method or moment distribution method, to analyze the structure shown below. Calculate and plot the shear force and moment diagrams. On both diagrams, label the maximum and minimum ordinates (Minimum ordinates are frequently negative values). In addition to the loading shown member ②-③ increases in length by 75 mm along its centre line because of an increase in temperature. All members have the same EI and are inextensible. $EI = 10.0 \times 10^6 \text{ kN m}^2$. Use symmetry where it applies.

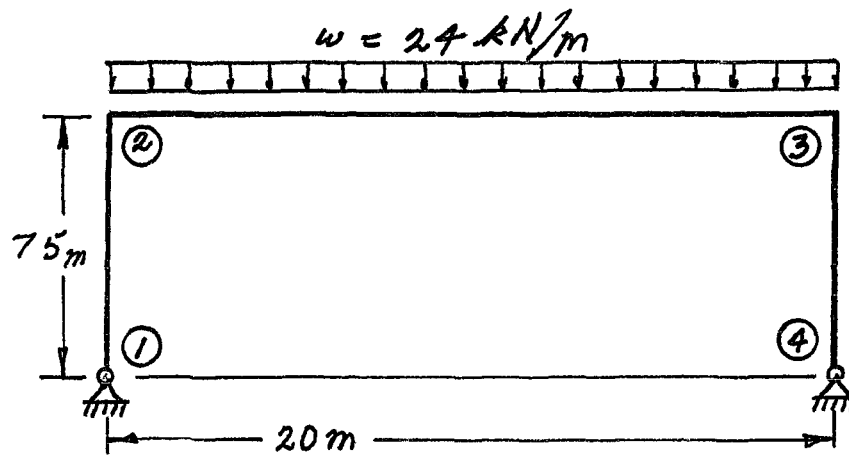

- (22) 7 Using a flexibility (force) method analyze the frame structure shown. All members have the same EI value and are inextensible. Draw shear and bending moment diagrams. On both diagrams for each member indicate the magnitudes of the maximum and minimum ordinates (Minimum ordinates are frequently negative values).

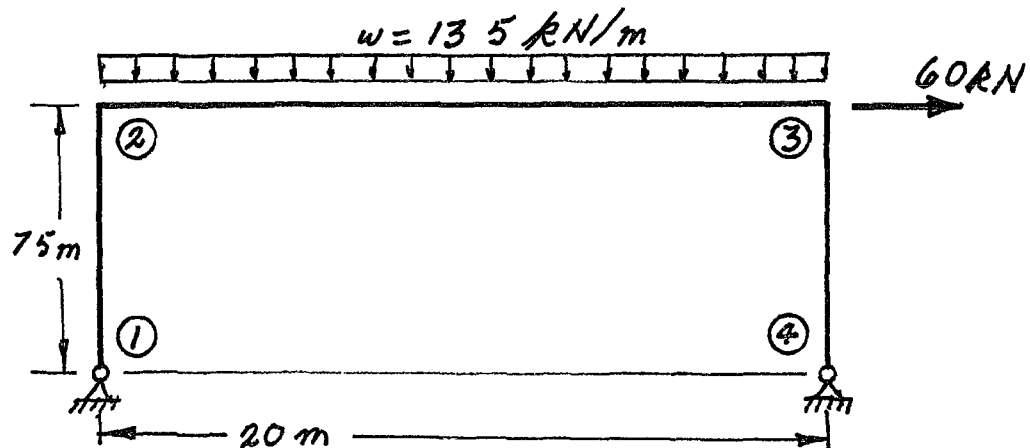

SELECT AND ANSWER TWO QUESTION ONLY FROM QUESTIONS 6 7 8 OR 9

- (22) 8 Using the slope deflection method or the moment distribution method, analyze the frame structure shown below. Plot shear force and bending moment diagrams. For both diagrams, on each member label the magnitude of the maximum and minimum ordinates (Minimum ordinates are frequently negative values). All members are inextensible and have the relative EI values shown. Take advantage of symmetry.

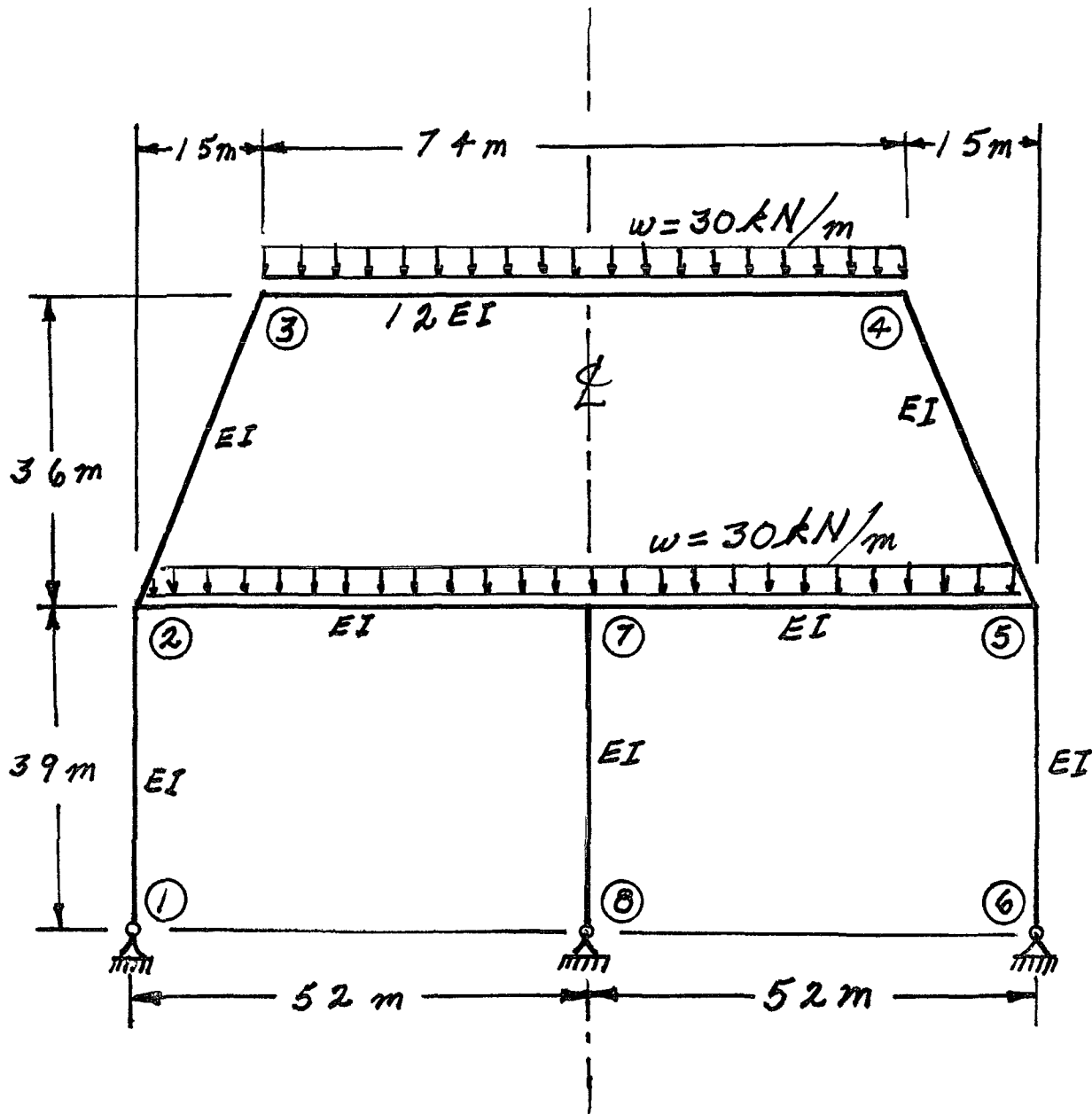

- (22) 9 a) For the frame shown, derive the equilibrium equation for the translation at joint ② indicated on the diagram. Neglect the effects of axial strain. All members have the same EI values.
- b) Derive the equilibrium equations for moment equilibrium at joints ② and ③.
- c) Present your results in matrix form by giving the terms of the stiffness matrix [K] and the load vector {P} in the following equation

$$[K] \begin{Bmatrix} \delta \\ \theta_2 \\ \theta_3 \end{Bmatrix} = \{P\}$$

DO NOT SOLVE THE EQUATIONS

The unknowns of the problem shall be

δ = translation at joint ② (positive in the direction indicated)

θ_2 = rotation of joint ②
 θ_3 = rotation of joint ③ } (positive counter clockwise)

