

National Exams May 2009

04-Bio-A4, Biomechanics

3 hours duration

NOTES

- 1 If doubt exists as to the interpretation of any question, the candidate is urged to submit with the answer paper, a clear statement of any assumptions made
- 2 This is a CLOSED BOOK EXAM
Only approved Casio or Sharp calculators are permitted
- 3 FIVE questions constitute a complete exam paper
- 4 Each question is of equal value
- 5 Clarity and organization of the answers are important, please draw and write clearly

1 A soccer player kicks a ball using their flexors in their hip joint Their pelvis is stationary Their leg has a mass of 12.5 kg, a radius of gyration of 240mm, the toe accelerates at 18 m/s^2 and has specific dimensions as shown in the accompanying figure

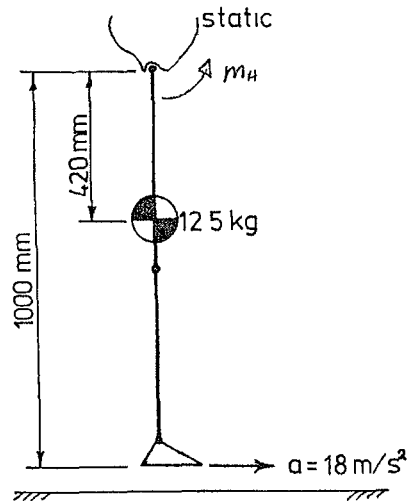

- a) **Calculate** the inertial force acting on the centre of mass for this action (4)
- b) **Calculate** the inertial torque acting on the centre of mass for this action (4)
- c) Assuming that the pelvis is stationary and is not experiencing any accelerations and that the knee remains extended, **draw** the free body diagram necessary to calculate the hip moment that the hip musculature must generate to produce this activity (4)
- d) **Calculate** the hip moment that the hip musculature must generate to produce this activity (8)

2 During water ski tournaments, skiers travel around a series of buoys. To successfully reach the next buoy, they must accelerate aggressively as they exit the turn from the previous buoy. Rope loads during this acceleration are very high and the resulting acceleration is dramatic. The skier shown here is accelerating out of a turn at a buoy. This photo was taken from the boat and the buoy is hidden behind the skier.

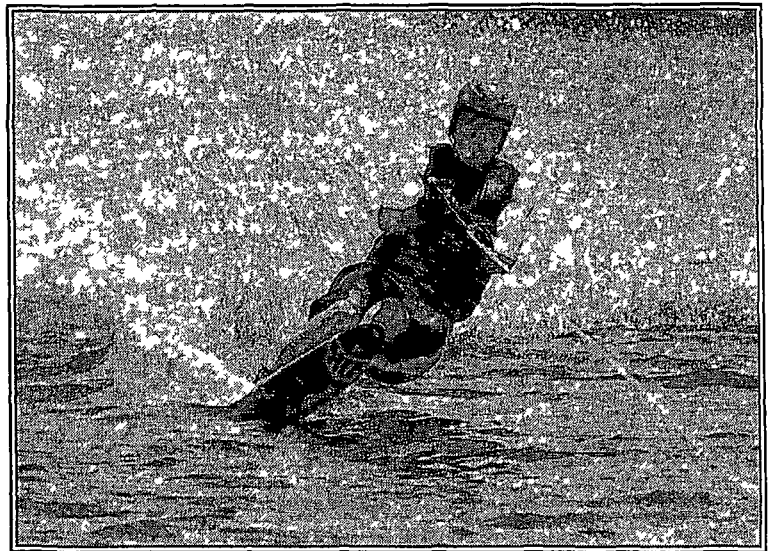

You have been asked to help a local waterskiing school analyse some data and photos from a ski tournament. The image shown on the right was taken from directly above the skier and corresponds to the same instant as the image above. Nominal rope force, F_{nom} , for this skier travelling directly behind the boat was recorded earlier as 400N. Rope force for the instant shown, F_{rope} , was measured as 1500N. The dashed line and arrow shows the direction of travel for the skier.

The following data is known

- Skier mass, $m_s = 70 \text{ kg}$
- Skier equipment mass, $m_e = 5 \text{ kg}$
- Boat velocity, $V_b = 54 \text{ kph}$
- Skier minimum velocity, $V_{smin} = 16 \text{ kph}$
- Skier maximum velocity, $V_{smax} = 67 \text{ kph}$

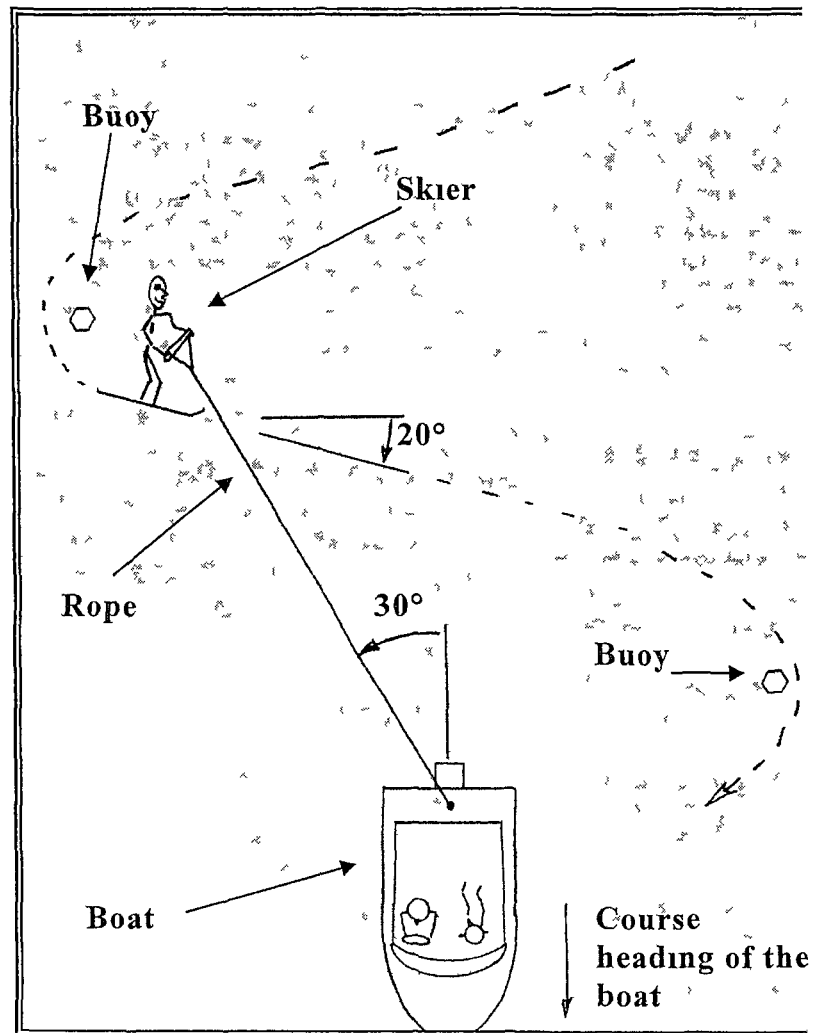

- a) Draw a free body diagram for the skier at the instant shown (8)
- b) Calculate the skier's acceleration in the indicated direction for the instant shown and state any significant assumptions that you used to arrive at your answer (12)

- 3 A skier who misjudged an extreme skiing cornice jump is now a patient with a lower limb fracture. The patient is lying on a bed and with their limb supported by traction pulleys and a weight. Subject mass is 80 kg and their height is 1.75 m. If the traction force is applied through the ankle centre, answer the following questions.

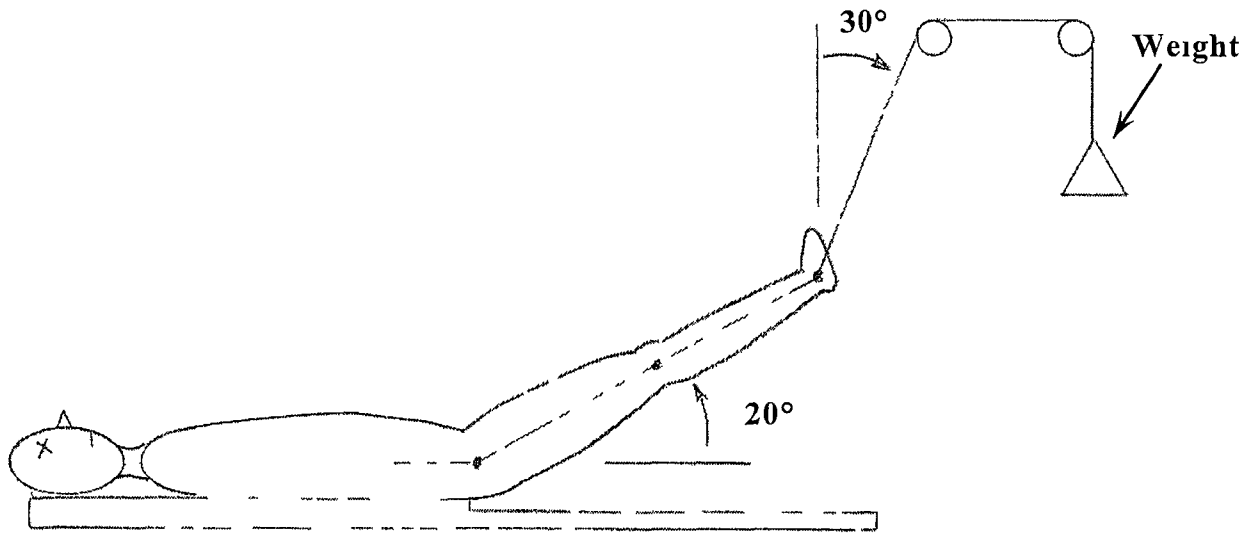

Use the following information to answer the questions below.

Hip to ankle length, $l_{leg} = 0.86 \text{ m}$
 Hip to centre of mass position, $l_{cm} = 0.36 \text{ m}$
 Leg mass, $m_{leg} = 12 \text{ kg}$

- Draw** a free body diagram for the skier's leg. (8)
- Calculate** the mass required to keep the patient's leg elevated as shown in the diagram. (6)
- Calculate** the hip joint loads created when the patient's leg is elevated as shown in the diagram. (6)

4 A biomechanist is trying to model the behaviour of the human spine using standard viscoelastic spring and dashpot modelling techniques. The model is going to be used to investigate the daily lengthening and shortening the spine undergoes due to the effects of gravity.

Two models are being considered. In Model A, each vertebra and each disk are modelled as Kelvin solids. In Model B they are Maxwell fluids. In both models, the results for all the vertebra and disks are combined to yield results for the overall spine. Samples of both models are shown below,

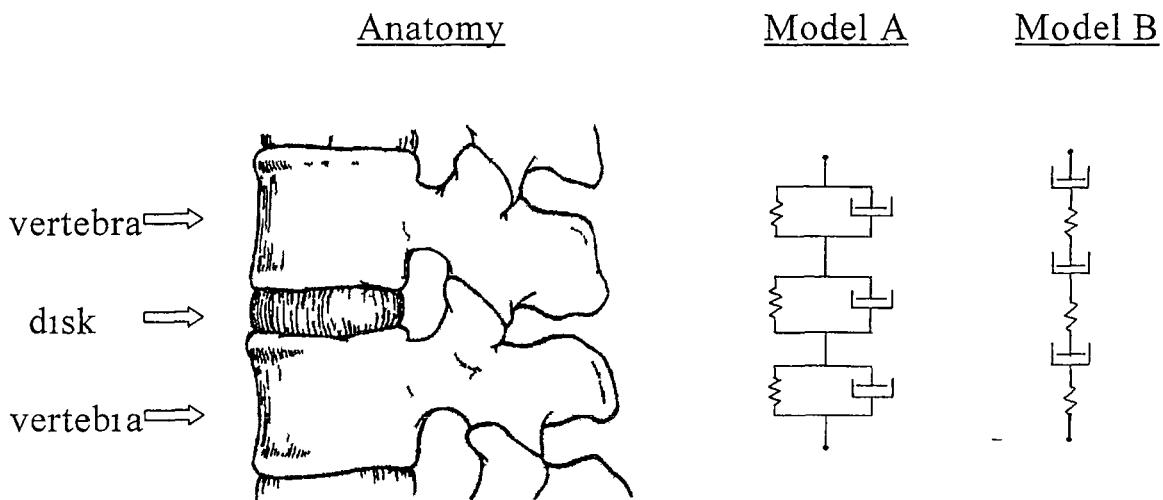

It is known that the spine begins to shorten immediately after getting up in the morning, and within a few minutes it stabilizes at its day-time length.

- a) **Choose** the model that you feel will best represent the behaviour of the spine. **Explain why**. (6)

- b) **Draw** what you would expect the strain vs time and stress vs time relationship would be for the spine over a typical 24 hour period in the life of a student. **Clearly label** the important events. (8)

- c) **Choose** which test, either step strain or a step stress, will be most appropriate for validating the spine model? **Explain** your choice. (6)

- 5 A subject's right hip joint is subjected to 120 Nm tending to adduct and 30 Nm tending to flex the joint. Two muscles, gluteus medius (GM) and rectus femoris (RF) may be active to balance these moments. For the idealised lines of action of these muscles calculate the muscle forces required for equilibrium in the two views given. Also calculate the three components of force applied to the femoral head by the acetabulum.

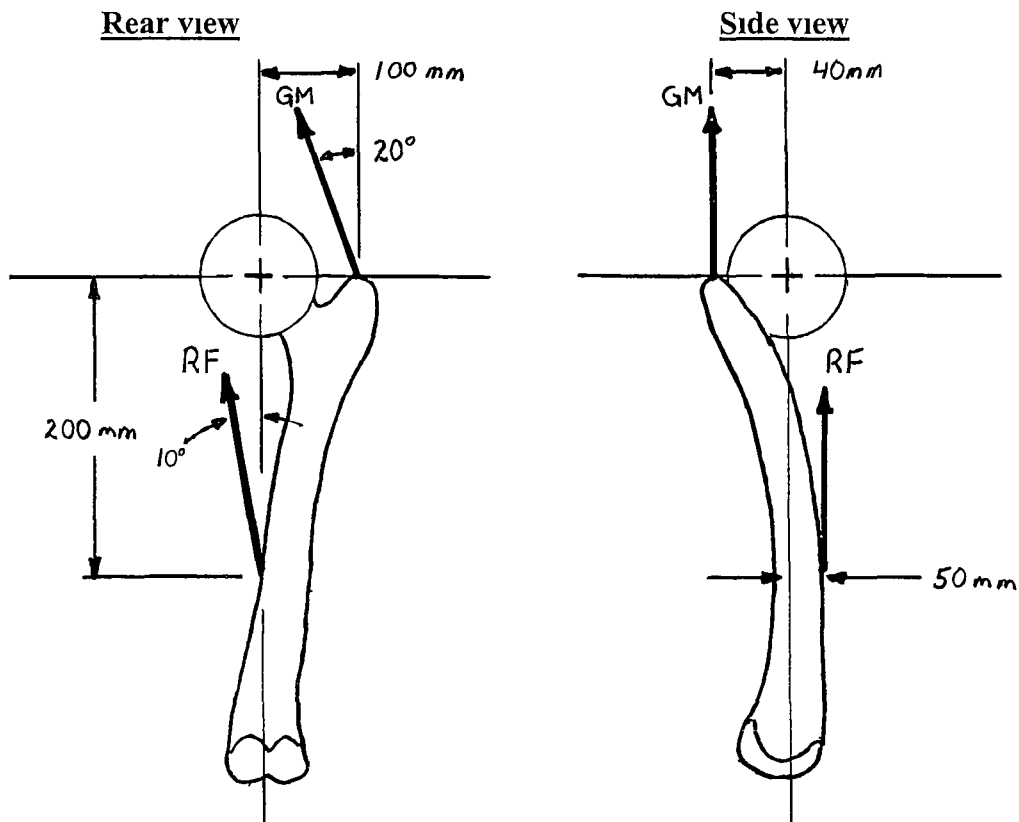

Marking Scheme

- 1 20 marks total (4 parts- 4, 4, 4 & 8 marks respectively)
- 2 20 marks total (2 parts- 8 & 12 marks respectively)
- 3 20 marks total (3 parts- 8, 6 & 6 marks respectively)
- 4 20 marks total (3 parts- 6, 8 & 6 marks respectively)
- 5 20 marks total (1 part- 20 marks respectively)