

National Exams May 2010

04-Chem-B6 - Petroleum Refining and Petrochemicals

3 hours duration

NOTES:

1. If doubt exists as to the interpretation of any question, the candidate is urged to submit with the answer paper, a clear statement of any assumptions made.
2. This is a CLOSED BOOK EXAM.
Any non-communicating calculator is permitted.
3. FIVE (5) problems constitute a complete exam paper.
The first five problems as they appear in the answer book will be marked.
4. Each problem is of equal value.
5. Note that the questions (a), (b), (c), (d), (e), (f) or (g) of each problem can be treated independently.
6. Most questions require an answer in essay format. Clarity and organization of the answer are important. Some of the questions require calculations please show all your steps.

Problem 1 (20 marks)

- (a) Explain briefly and concisely what are the main functions of a carburettor for a spark-ignition engine.
4
- (b) Explain concisely, what are the main physical characteristics of fuel that can influence carburetion
4
- (c) Explain briefly why crude oil needs to be refined and how this is done.
4
- (d) A coal containing 81 weight percent total carbon and 6 weight percent unoxidized hydrogen is burned in refinery furnace, in dry air. The rest of the coal is solid inert, also called ash. The amount of air used is 30% more than is theoretically required to completely oxidize all of the carbon to CO_2 and all of the hydrogen to H_2O . Calculate the number of kg of air per kg of coal and the composition of the stack gas leaving the furnace, assuming this gas contains no carbon monoxide (CO).
8

Problem 2 (20 marks)

- (a) Explain in a concise manner:
2
4
4
- (i) What is the anti-knock quality of a gasoline and
- (ii) How the anti-knock quality of a gasoline is determined
- (iii) What is used by the petroleum industry to reduce knock
- (b) The absorber shown in the diagram below is used to remove benzene from contaminated air. Calculate the flow rates of streams 1 and 2 in (kg/hr).

10

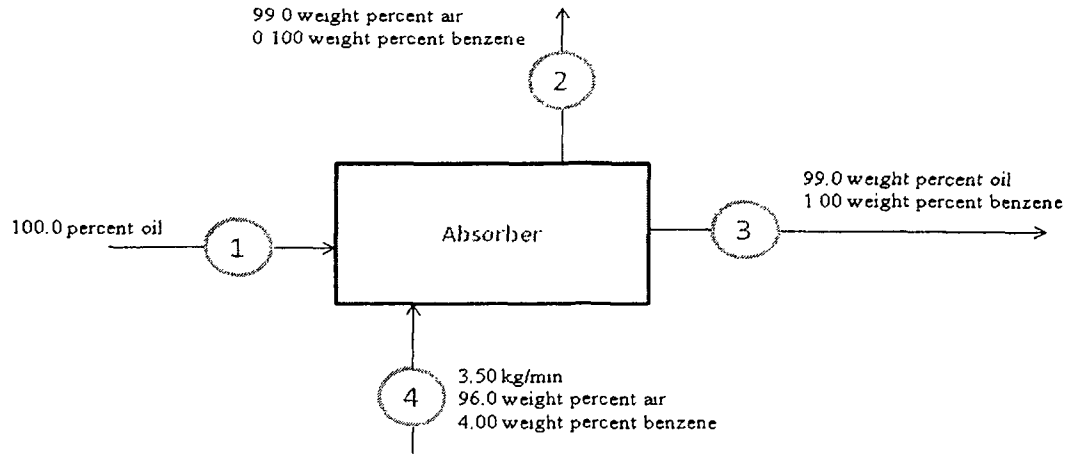

Problem 3 (20 marks)

- (a) Explain briefly what is alkylation for the petro-chemical industry?
2
- (b) What are the most important factors that must be considered by a refinery to select a particular alkylation process?
4
- (c) Explain why the above factors for alkylation are so important.
4.
- (d) The schematic diagram below depicts a portion of the process that produces styrene from benzene and ethylene. Benzene is recycled to an alkylation reactor and the by-product ethylbenzene is recycled to a dehydrogenation reactor. Stream 2 is 28% of Stream 1. Also 97% of the ethylbenzene in Stream 3 leaves distillation column 2 via stream 4. Calculate the flow rate and composition of Stream 5.
10

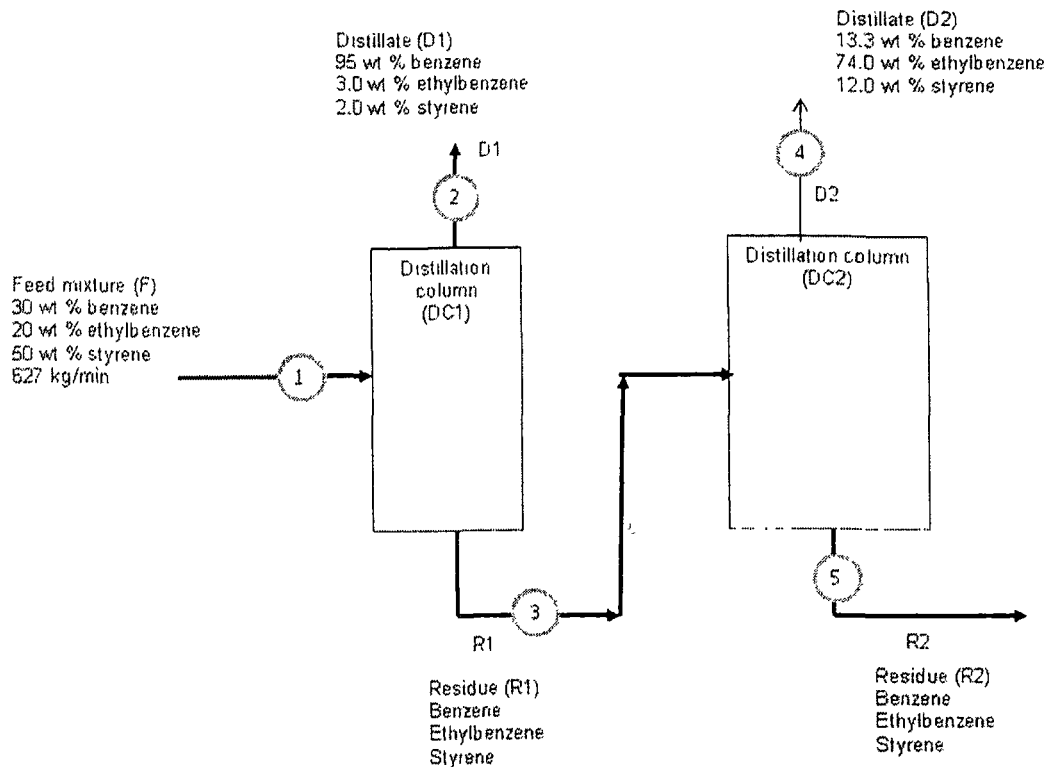

Problem 4 (20 marks)

(a) As a petrochemical engineer, your role is to run your plant as efficiently as possible while complying with several environmental restrictions or guidelines.

(i) List a few of the potential environmental risks (to air, land and water) from a petroleum refinery.

3

(ii) What you would do to prevent these risks from occurring?

3

(b) List four key design parameters for a hydrocracking reactor.

2

(c) Explain why the above reactor design parameters are important.

2

(d) A vapour stream entering a sieve plate (shown below) in a distillation column contains 40 mole percent of benzene and 60 mole percent of toluene. Its flow rate is 550 kg-mole/hr. Liquid flows into the tray at a rate of 700 kg-mole/hr and with a composition of 45 mole percent benzene and 55 mole percent toluene. Under the conditions on the plate, the composition of the vapour leaving the tray (y mole fraction benzene) is related to the composition of the liquid leaving the tray (x mole fraction benzene) by the simple equation:

$$y = 1.3x$$

The liquid and vapour streams leaving the plate have the same total molar flow rates as those entering the plate.

Calculate the compositions of the streams leaving the plate.

10

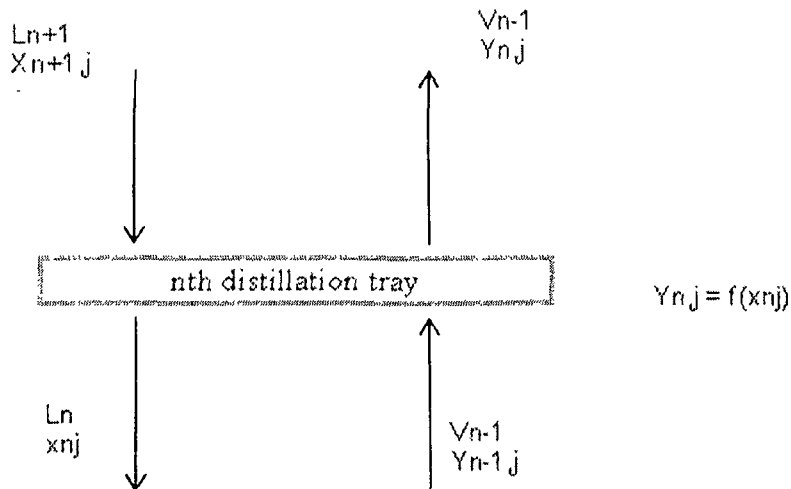

Problem 5 (20 marks)

(a) Explain briefly how the following gases can be removed from valuable product streams:

- (i) Hydrogen sulphide (H_2S)
2
- (ii) Carbon dioxide (CO_2)
2
- (iii) Low aliphatic mercaptans
2

(b) Several processes are used in modern refineries to produce hydrogen. Describe in a clear and concise manner two of the processes used in modern refineries to produce hydrogen?

4

(c) The chemical reaction to produce ammonia is the following:

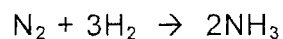

- (i) Design using a flow sheet, a process or series of processes that would produce pure ammonia (NH_3) if you only have as raw materials, the following feedstock: air, methane (CH_4) and water. You can use any process or unit operation you judge suitable.
- (ii) Describe in a concise manner how the process you have designed above works.

Hint:

- (1) Air contains two elements that might be of interest.
- (2) You may think of processes that can be used to purify your raw materials.
- (3) With the feedstock you have access to and with your petrochemical knowledge you should be able to produce on site, all raw materials you would need.

10

Problem 6 (20 marks)

- (a) Describe briefly the main classes of wax produced from crude oils.
3
- (b) Provide in a concise manner the main characteristics of these waxes.
3
- (c) Explain briefly what is meant by "cracking" in the hydrocarbon industry.
2
- (d) Give a brief description of the main cracking processes and what are their relative advantages?
4
- (e) Explain briefly and concisely what is an isomerisation Unit and in which product(s) isomerates are used.
2
- (f) Calculate the flow rate (in kg/min) and composition of the effluent from the mixer shown below.
6

