

National Exams May 2010

98-Civ-B8, Management of Construction

3 hours duration

Notes:

1. If doubt exists as to the interpretation of any question, the candidate is urged to submit with the answer paper, a clear statement of any assumptions made;
2. This is a "Closed Book" exam. Candidates may use one of two calculators, the Casio or the Sharp approved models;
3. Any five questions constitute a complete paper. Only the first five questions as they appear in your answer book will be marked.
4. All questions are of equal value.

Marking Scheme

7. 20 marks
8. 20 marks
9. 20 marks
10. 20 marks
11. 20 marks
12. 20 marks

1. Scheduling:

For the following network: Calculate ES, LF, & TF for all activities; Identify the critical path; and Draw a Late Bar Chart for the project. What is the effect of delaying activity "G" by five days on the total project duration?

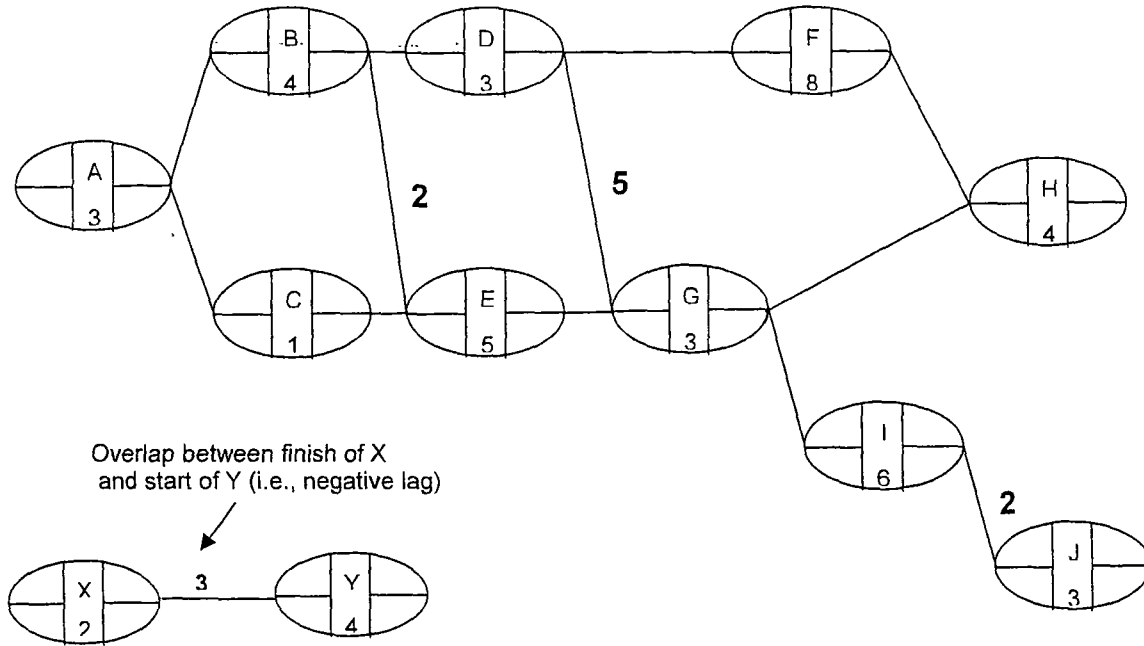

2. Contract Administration:

Discuss the project environment that best suits the following contractual approaches: Unit Price, Turnkey, and Cost plus a Guaranteed Maximum Price. Also, discuss the level of risk carried by both the owner and the contractor organizations in each of the three contractual approaches.

3. Labor Relations:

Discuss the pros and cons of hiring unionized versus non-unionized labor for your construction project.

4. Engineering Economics:

A town is considering building a new bridge and two proposals have been put forward. The costs of each proposal are summarized in the following table. With the cost of capital at 10%, which proposal should be used (using present worth).

	Bridge A	Bridge B
Initial cost of bridge	\$6,500,000	\$5,000,000
Initial cost of roads	\$3,500,000	\$3,00,000
Annual maintenance of bridge	\$7,000	\$9,000 for first 10 years and \$11,000 thereafter
Annual maintenance of roads	\$3,000	\$2,500
Life of bridge	60 years	30 years
Life of roads	60 years	60 years

5. Project Control:

- (a) Sketch and briefly explain the general trend of a typical S-Curve.
- (b) Replace the question mark by the appropriate indication of cost and schedule:

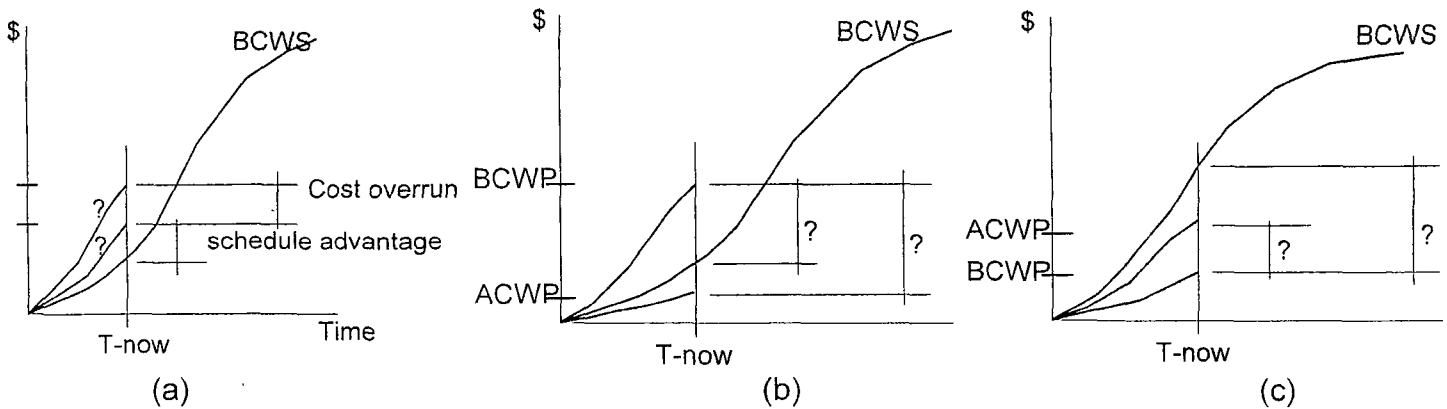

6. Productivity:

Discuss the factors that can impact workers productivity on construction sites. Discuss briefly how productivity can be measured and ways to improve it.