

Front Page

National Exams December 2009

04-Chem-B6 - Petroleum Refining and Petrochemicals

3 hours duration

NOTES:

1. If doubt exists as to the interpretation of any question, the candidate is urged to submit with the answer paper, a clear statement of any assumptions made.
2. This is a CLOSED BOOK EXAM.
Any non-communicating calculator is permitted.
3. FIVE (5) problems constitute a complete exam paper.
The first five problems as they appear in the answer book will be marked.
4. Each problem is of equal value.
5. Note that the questions (a), (b), (c), (d), (e), (f) or (g) of each problem can be treated independently.
6. Most questions require an answer in essay format. Clarity and organization of the answer are important. Some of the questions require calculations please show all your steps.

Problem 1 (20 marks)

- (a) Explain briefly why crude oil needs to be refined and how this is done.

4

- (b) What are the most common leading features used for the specification of the following petroleum products:

- i. Gasoline
- ii. Naphtha and kerosene
- iii. Gas oils
- iv. Fuel oils
- v. Lubricating oils
- vi. Asphalts

6

- (c) Consider two distillation columns operating in series as shown below. A 100 kg/h feed mixture (F) containing 40% benzene, 30% xylene and 30% toluene is fed to a distillation column (DC1). The distillate (D1) from DC1 is almost pure in benzene; it contains 99.5% benzene and only 0.5% toluene. The residue (R1) from DC1 is fed to a second distillation column (DC2) from which a distillate (D2) of composition 97% toluene, 2% benzene and 1% xylene and a residue (R2) of composition 5% toluene and 95% xylene are obtained.

- i. Determine the mass flow rates of the three final streams (D1, D2 and R2) from the system.
- ii. Find the mass flow rate of the intermediate stream R1.
- iii. Determine the composition of R1.

10

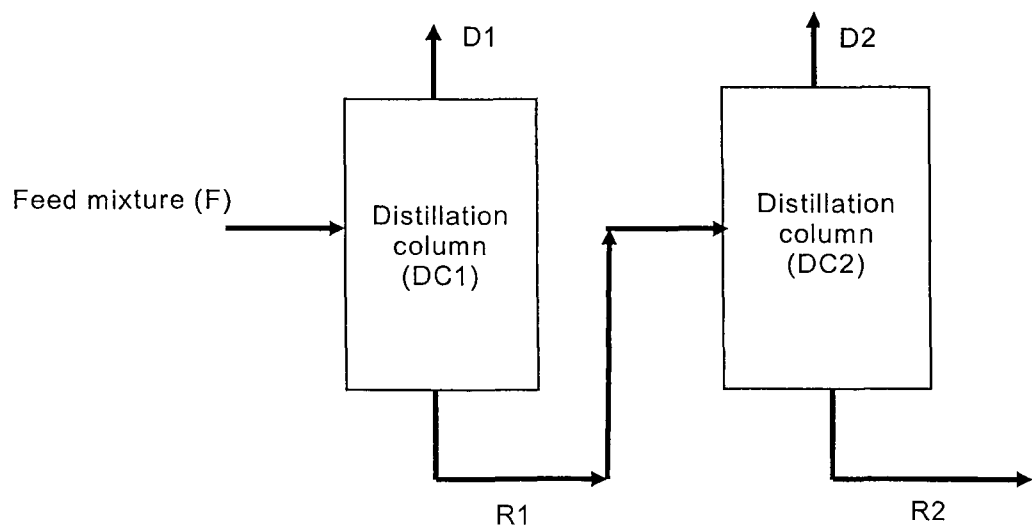

Problem 2 (20 marks)

- (a) Describe briefly what is reforming for a petroleum refinery.
(i) Write the reforming reactions using for example the methane steam reaction.

4

- (ii) Explain the impact of temperature and pressure on this reaction.

2

- (b) Explain briefly what is solvent dewaxing and which product it is used for?

4

- (c) In one of the processes for making absolute alcohol from an alcohol mixture containing 5% by weight of water, a third component benzene is added to the alcohol feed. Benzene lowers the volatility of alcohol and takes the entire water impurity overhead as a constant boiling mixture of composition 18.5% alcohol, 7.5% water and 74% benzene. The residue from the still is absolute alcohol. Calculate (i) the amount of benzene and (ii) impure alcohol required for the production of 2500 kg of absolute alcohol.

10

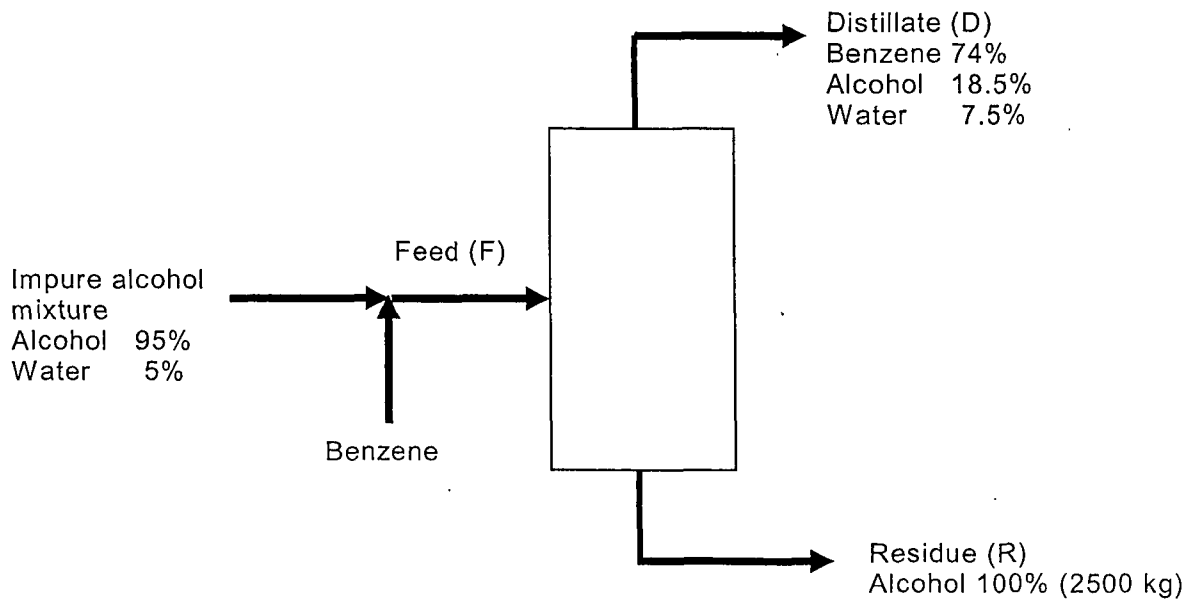

Problem 3 (20 marks)

- (a) If salt content of a crude oil is greater than certain level, the crude requires desalting.
- (i) Explain the main reasons why salty crude oils need to be desalted.
- 2
- (ii) Describe concisely how the desalting process is done.
- 2
- (b) There are two types of octane numbers for gasoline engines: those determined by the motor method (MON) and those determined by the research method (RON).
- (i) Explain briefly the difference, if any, between the two methods
- 2
- (ii) Describe clearly and concisely what these two octane numbers represent.
- 4
- (c) A furnace in a petroleum refinery uses coke that contains 80% carbon, 0.5% hydrogen and 19.5% ash by weight. It operates with 50% excess air and the ash formed contains 2% unburned carbon. 95% of the carbon burned in the furnace forms carbon dioxide and the balance carbon monoxide.
- (i) Write the equations of the main chemical reactions that would occur
- (ii) Calculate the composition of the flue gas at the furnace exit
- (iii) Calculate the weight of ash produced per 100kg of coke burned.
- (iv) Calculate the weight of carbon lost per 100 kg of coke burned.
- 10

Note: Specific information about air

- Average molecular weight of air is 29;
- Volume or mole per cent of oxygen in air is 21 vol % or 21 mol %.
- Weight percent of oxygen in air = 23%
- 1 kmol of air at normal temperature and pressure occupies 22.4 m³.
- In air, 1 mol of oxygen is accompanied by 3.76 mol of nitrogen.

Problem 4 (20 marks)

- (a) Explain briefly and concisely the meaning of the following terms:
- (i) Flash point
- 3
- (ii) Pour point
- 3

(iii) Explain briefly what is meant by “visbreaking” in the petroleum industry.

2

(iv) What are the principal reactions that occur during a visbreaking operation?

2

(b) Absorption of sulphur dioxide is carried in a packed tower as shown below. A gas stream containing 14.8% of sulphur dioxide and the rest inert gases enters the tower while the leaving gases contain 1% sulphur dioxide. Water flows at the rate of $1 \text{ m}^3/\text{min}$. The tower handles $7380 \text{ m}^3/\text{h}$ of gas at 303 K and 1 bar.

i. Find the sulphur dioxide concentration of the effluent from the tower.

ii. Find the volume of the gases leaving the tower at 0.95 bar and 293 K.

10

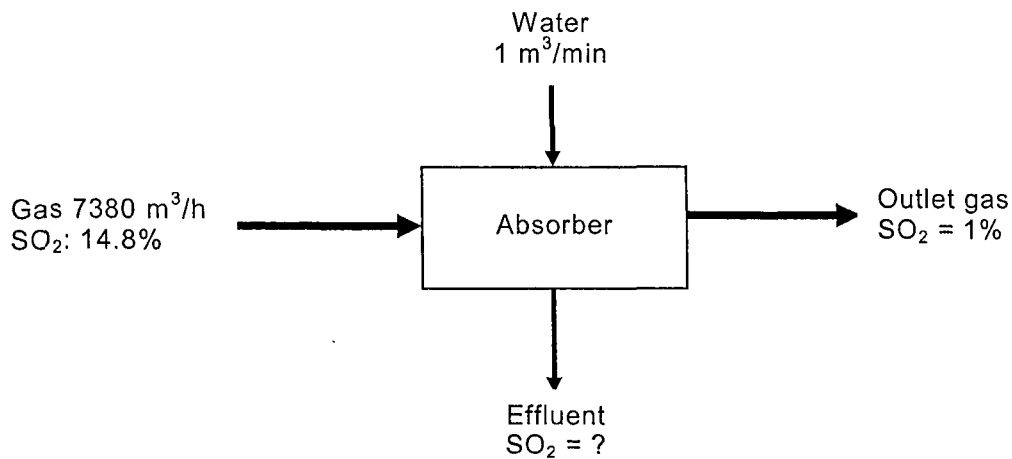

Problem 5 (20 marks)

(a) Several processes are used in modern refineries to produce hydrogen. Describe in a clear and concise manner two of the processes used in modern refineries to produce hydrogen?

4

(b) Use a flow sheet to provide a brief description of an alkylation unit.

4

(c) What are the standard catalyst types and typical feedstock used for alkylation?

2

(d) The naphtha cracking process is frequently used to produce light olefins.

(i) Explain briefly and concisely how you would increase the yield of light olefins in a naphtha cracker?

2

(ii) Explain clearly and concisely why steam is introduced in the tubes of the naphtha cracker?

2

(e) Graph the relationship between the theoretical number of stages in a distillation column and the reflux ratio.

3

(i) Show on the graph, where might be the optimum reflux ratio, the *minimum reflux* and the *minimum number of stages*.

3

Problem 6 (20 marks)

(a) Explain briefly and concisely what is an isomerisation Unit and in which product(s) isomerates are used.

2

(b) Describe briefly and in a concise manner the typical flow sheet of an isomerisation unit. Indicate the main reactions and equipment used.

4

(c) Explain briefly what is the cloud point of a petroleum product

2

(c) Provide a concise definition of API gravity and show how it relates to specific gravity.

2

(d) 5000 barrels of 28° API gas oil are blended with 20,000 barrels of 15° API fuel oil. What is the density of the mixture in the following units:

- i. Lb per US Gallon
- ii. Lb per ft³.

Note: Assume that the volumes are additive.

1 barrel = 42 US gallons

The density of water at 60 °F is 0.999 g/cm³.

10