

National Exams December 2009

07-Mec-B1, Advanced Machine Design

3 hours duration

Notes

1. Answer all questions of Part I (i.e., Questions 1 & 2) and only TWO questions from Part II of the examination.
2. Make your answers neat; write your equations in symbol form first and put intermediate and final results in boxes.
3. State all assumptions clearly. If doubt exists as to the interpretation of any question, the candidate is urged to submit with the answer paper, a clear statement of any assumptions made.
4. All answers must be clearly annotated with a summary of the approach, method, and results written in clear and correct English.
5. This is an OPEN BOOK EXAM. One textbook of choice plus notes.
6. Any non-communicating calculator is permitted.
7. Assume any missing data and make sure to properly state it in your answer.
8. The examination marks total 100.
9. Failure to follow the above directions will result in the grade penalties.

Part I

Questions 1 and 2 must be solved by all candidates.

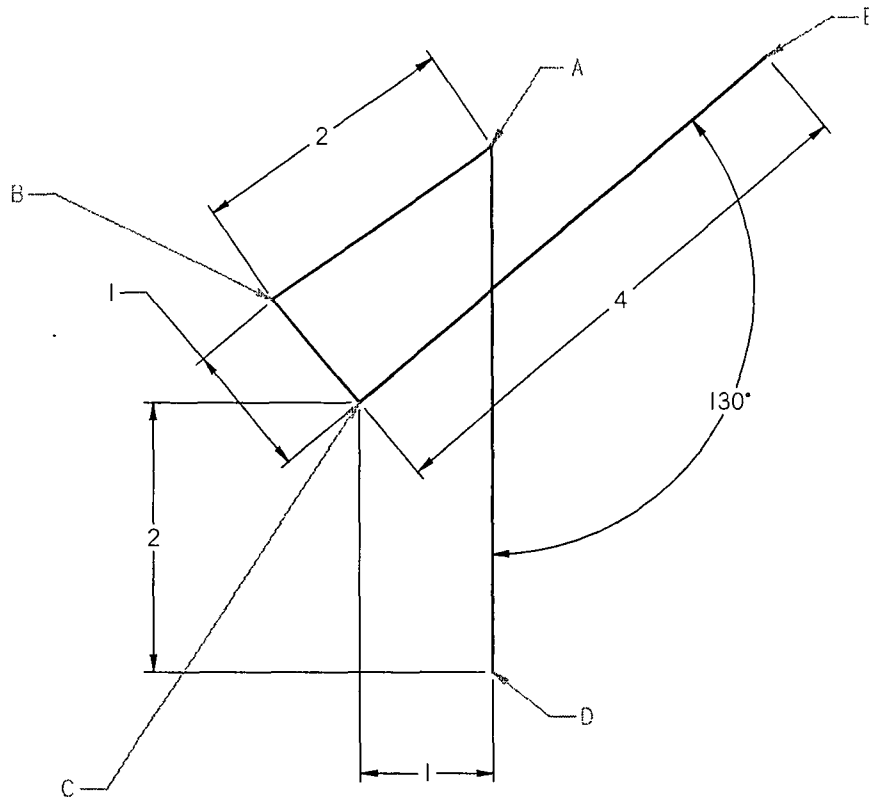
Question 1 (25 points)

The above diagram is schematic of a small manual press or juicer. Points C and D are grounded. Link AD has variable length. Link AB is fixed length. Link BCE is rigid with a right angle between lines BC and CE. The dimensions are in inches. The user exerts a force up at E causing A to be displaced down for the given position of 130 degrees. For this position, determine the following.

- i. The ratio of vertical force provided by the user at E to the output force at A.
- ii. The ratio of displacement in the vertical direction at E to the vertical displacement at A.

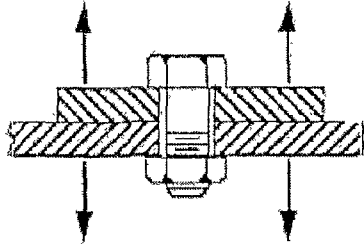
Question 2 (25 points)

Two grade 252 cast-iron components, carrying a static load of 10 kN and each 20 mm thick, are held together by four bolts. The components are not intended to be separated again once built.

- i. Select metric bolts.
- ii. Determine k_b , k_m , and C .

Part II

Solve only two questions from the following three questions (3, 4, and 5).

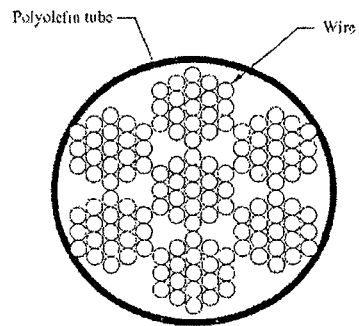
Question 3 (25 points)

The above schematic shows the cross-section of a cable manufactured from 7×19 braided carbon steel wire. The cable is subjected to twisting and bending that opens and closes the cable wire bundles during operation. The operating environment contains both moisture and salt.

To prevent corrosion, the 5 mm diameter steel wire cable is galvanized and covered with a weather resistant heat shrink tube made of cross linked polyolefin. The ends of the cable are sealed with epoxy during manufacturing.

List and then comment on five possible reasons why the galvanized cables might corrode and break within a few years of initial use and describe what could be done to improve the design.

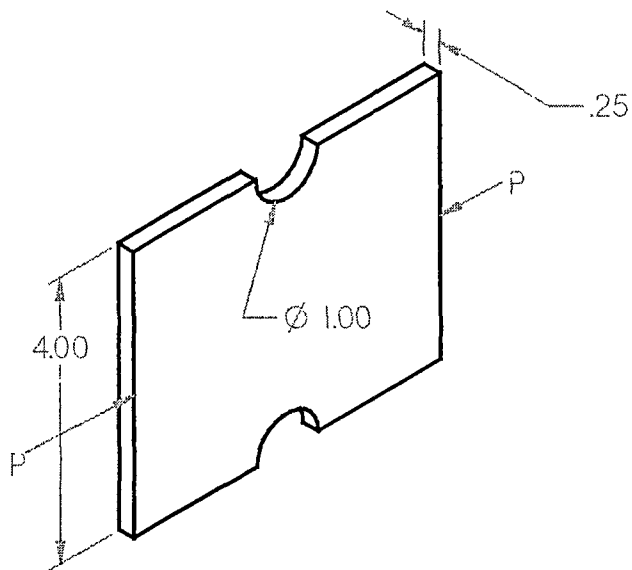
Question 4 (25 points)

A notched T6 aluminum alloy is show above. All dimensions are in inches. An axial load, P , of 400 kN is applied to each end.

- i. The dimension, .25, is the initial estimate sketched by an engineer. Verify that this value will prevent failure by yielding of the entire cross section between the notches. Offer a corrected value if necessary.
- ii. Make a drawing showing the approximate stress distribution with the given load applied.
- iii. Make a drawing showing the approximate stress distribution after the load is removed.

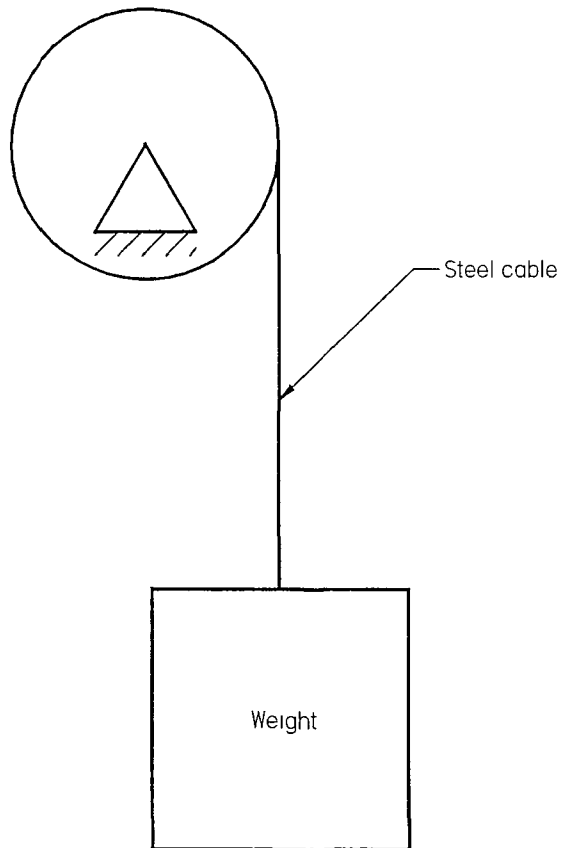
Question 5 (25 points)

Select a stranded steel cable for the above schematic. The cable must be able to withstand the sudden stop, from 10 m per minute, of the 1 ton weight.