

NATIONAL EXAMS MAY 2007

98-CIV-B1 ADVANCED STRUCTURAL ANALYSIS

3 HOURS DURATION

NOTES:

1. If doubt exists as to the interpretation of any question, the candidate is urged to submit with the answer paper a clear statement of any assumption made.
2. Candidates may use one of two calculators, a Casio or a Sharp otherwise, this is a CLOSED BOOK Examination.
3. Answer BOTH questions #1, and #2. Answer ONLY TWO of questions #3, #4, or #5. Answer ONLY TWO of questions #6, #7, #8 OR #9. SIX questions constitute a complete paper.
4. The marks assigned to each question are shown in the left margin.

FRONT PAGE

QUESTION #1 MUST BE ANSWERED.

- (8) 1. Indicate with arrows (\curvearrowright a rotation; \rightarrow a translation) on each structure and list beside each structure the number of structural degrees of freedom that are required to do an analysis by the slope-deflection method. In each case, use the minimum number of structural degrees of freedom; where they occur, take into account symmetry, anti-symmetry and joints that are known to have zero moments.

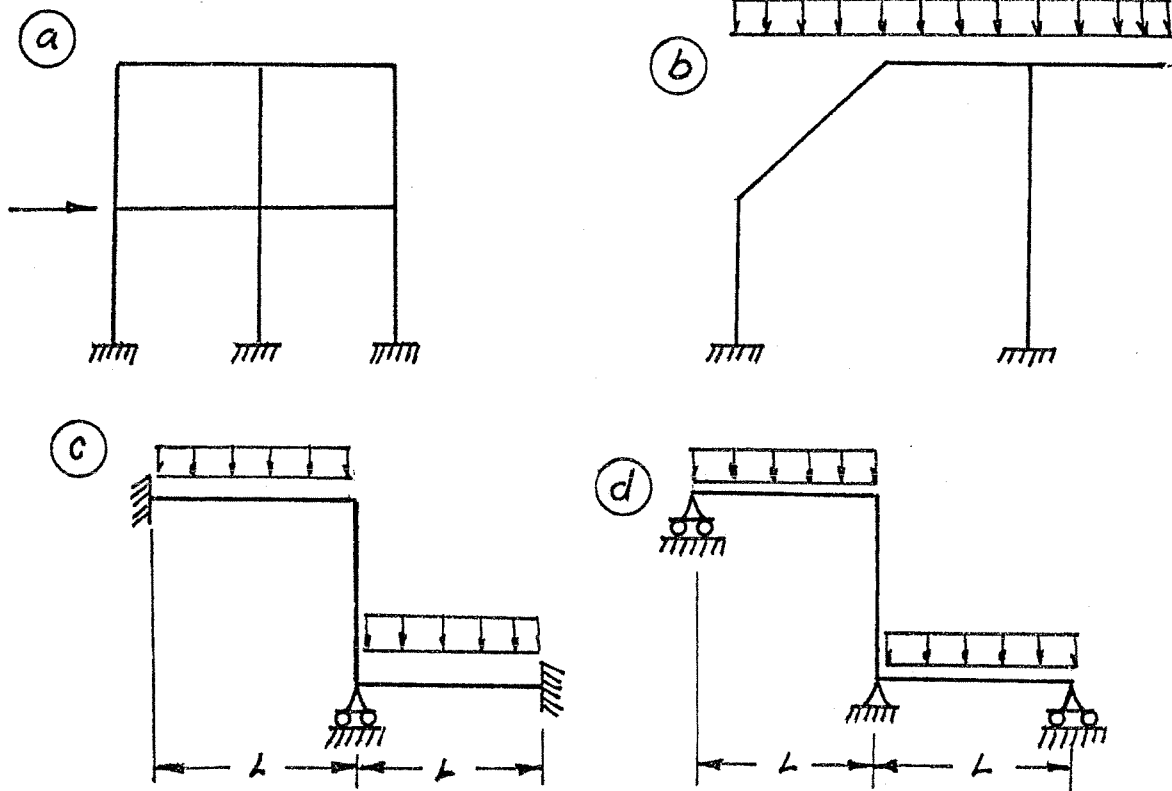

- (12) 2. Schematically show the shear force and bending moment diagrams for the following structures. All members have the same EI and are inextensible.

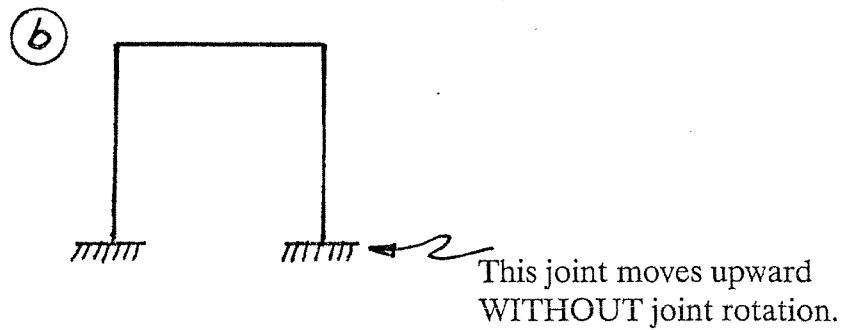
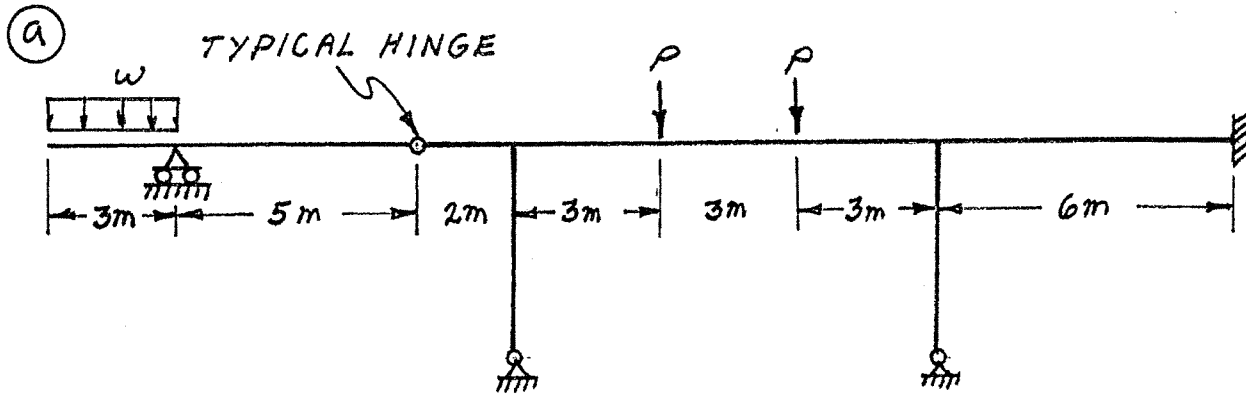

SELECT AND ANSWER TWO QUESTION ONLY FROM QUESTIONS 3, 4, OR 5.

- (16) 3. Use Castigliano's theorem (the least work theorem) to analyze the structure shown. Calculate the bending moment and shear on the beam at joint ①. Both members have the same EI value and are inextensible.

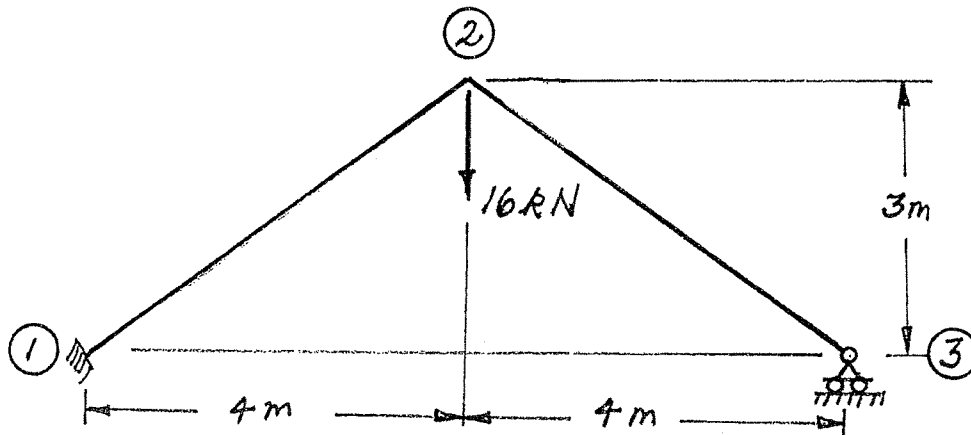

SELECT AND ANSWER TWO QUESTION ONLY FROM QUESTIONS 3, 4, OR 5.

- (16) 4. Loads are applied to the bottom chord of the pin-jointed truss shown below. Draw influence lines for forces in the following members and calculate and indicate the maximum ordinate values on the influence lines:

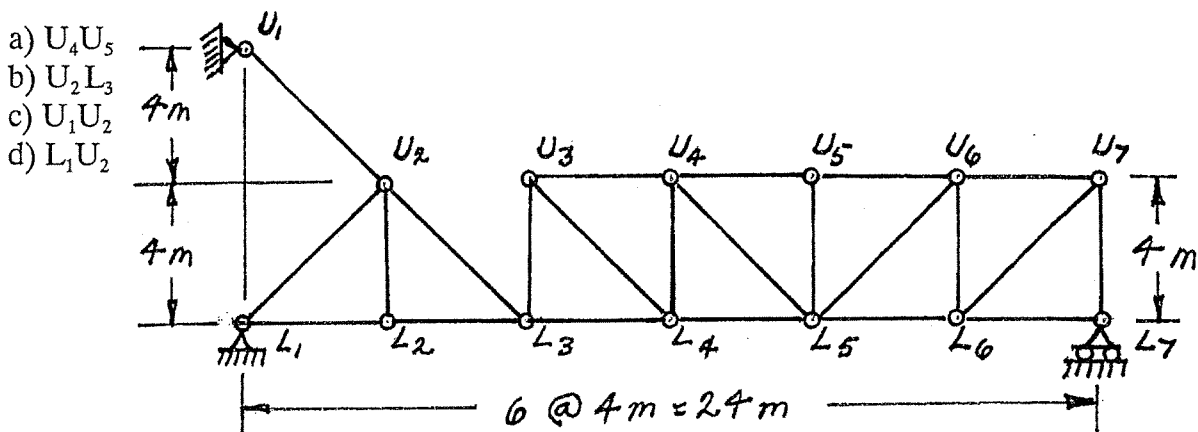

- (16) 5. Use the slope-deflection or the moment-distribution method to analyze the frame structure shown. Draw shear and bending moment diagrams. For each member on both diagrams, indicate the magnitude of maximum and minimum ordinates (Minimum ordinates are frequently negative). There are no loads on the structure, but because of temperature change the centre line of each member increases in length by 0.001 m . Neglect the strains caused by axial stresses and take advantage of symmetry. All members of the structure have the same EI value which is $1.5 \times 10^5\text{ kN.m}^2$.

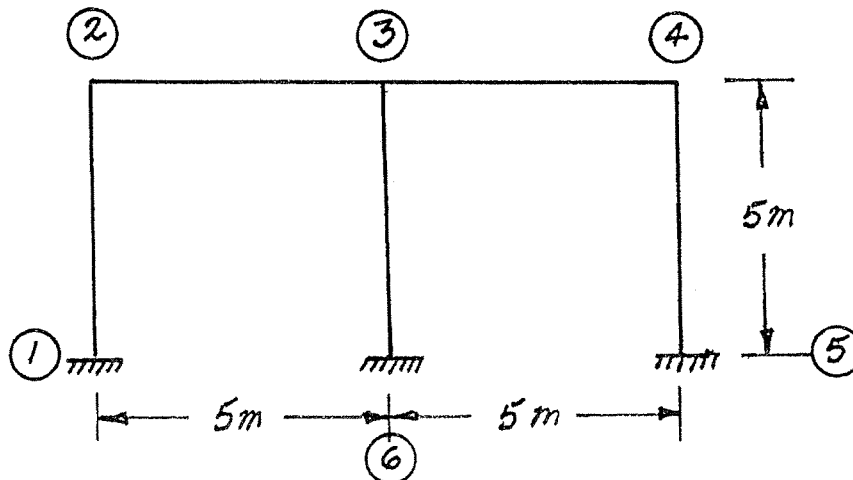

SELECT AND ANSWER TWO QUESTIONS ONLY FROM QUESTIONS 6, 7, 8 OR 9.

- (24) 6. Using the slope-deflection method or the moment-distribution method, analyze the frame shown. In addition to the effects of the uniformly distributed loading, stresses and strains are caused because the supports are each moved outward 2 mm as shown. Draw shear force and bending moment diagrams. On each diagram for each member, indicate the magnitudes of the maximum and minimum ordinates (Minimum ordinates are frequently negative). All three members are inextensible; and have an EI value of 10000 kN.m². Take advantage of symmetry.

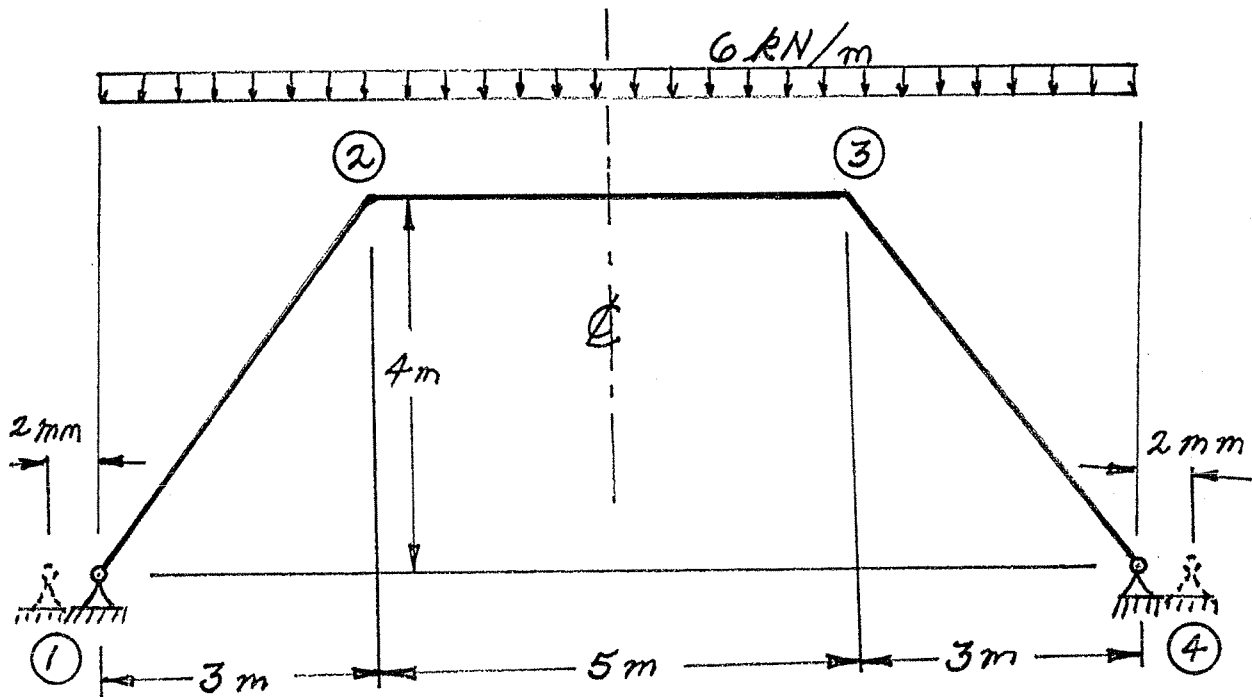

- (24) 7. Using a flexibility (force) method, determine the fixed-end moments for the non-prismatic beam with the distributed loading shown. Take advantage of symmetry.

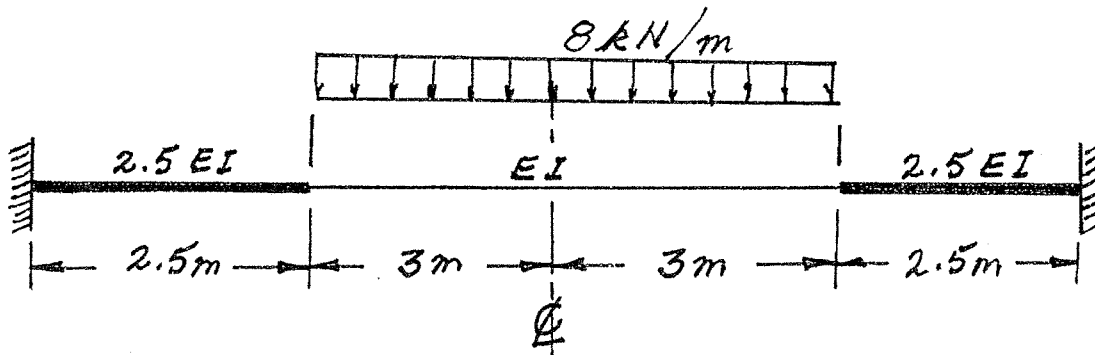

SELECT AND ANSWER TWO QUESTION ONLY FROM QUESTIONS 6, 7, 8 OR 9.

- (24) 8. Using the slope-deflection method, analyze the frame structure shown below. Plot shear force and bending moment diagrams. For each member on each diagram, indicate the magnitude of the maximum and minimum ordinates (Minimum ordinates are frequently negative). All members are inextensible and have the same EI value. Take advantage of anti-symmetry if and where it applies.

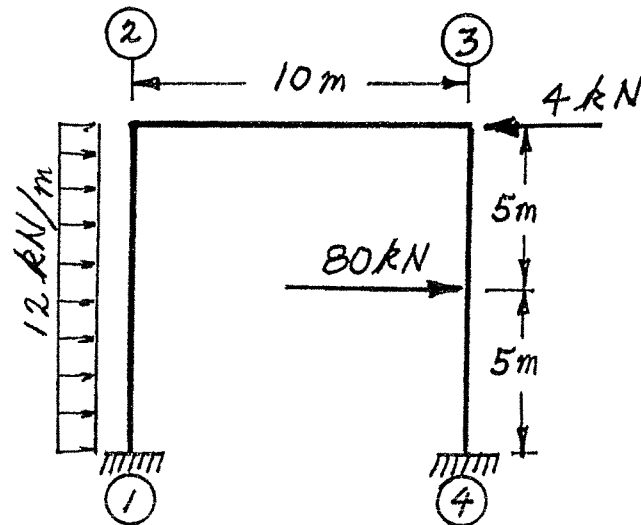

- (24) 9. a) For the frame shown, derive the equilibrium equation for translation at joint ②. Neglect the effects of axial strain. All members have the same EI value.
- b) Derive the equilibrium equations for moment equilibrium at joints ② and ③.
- c) Present your results in matrix form by giving the terms of the stiffness matrix [K] and the load vector {P} in the following equation:

$$[K] \begin{Bmatrix} \delta \\ \theta_2 \\ \theta_3 \end{Bmatrix} = \{P\}$$

DO NOT SOLVE THE EQUATIONS.

The unknowns of the problem shall be:

δ = translation at joint ② (positive in the direction shown)

θ_2 = rotation of joint ②
 θ_3 = rotation of joint ③

} (counter clockwise positive)

