

Professional Engineers
and Geoscientists of BC

This event is brought to you by the East Kootenay Branch of the Association of Professional Engineers and Geoscientists of BC. For more information on engineers and geoscientists and what they do, check out:

<http://www.apeg.bc.ca>

<http://www.new-sng.com>

<http://bridgecontest.usma.edu/download.htm>

<http://jhu.edu/~virtlab/bridge/bridge.htm>

**Contest Rules
For the
East Kootenay Branch
Annual Popsicle
Stick Bridge**

Construction:

1. Each contestant will receive 150 popsicle sticks, one bottle of wood glue and a sheet of construction paper in their registration kit.
2. The bridge must be built with a maximum of 100 popsicle sticks and the supplied white glue. The construction paper provided in the registration package must only be used as the deck of the bridge. Note that sticks are to be joined with white glue only. Sticks that are pinned together will be disqualified.
3. A matchbox car (50 mm wide x 40 mm high) must be able to be rolled across the bridge.
4. All Popsicle sticks must be left whole. They may not be cut or modified in any way.
5. The bridge must span a 50 cm (20") gap and be a maximum of 60 cm (24") long. It is best to make the bridge about 55 cm long. See drawing. The bridge must be free to move along the direction of the roadway when on the supports. **Please be careful to ensure that your bridge is long enough!!!** Several bridges in past could not be tested because they were too short.

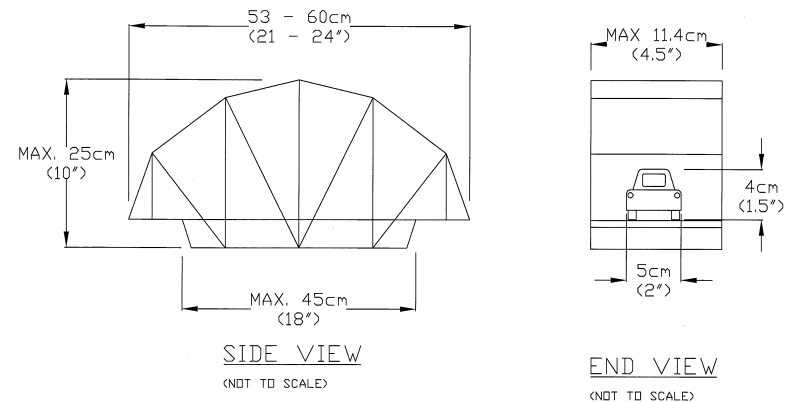

Testing the Bridges:

1. **Bridges will be weighed before loading. In the event of a tie, the lightest bridge wins.**
2. **The test load (weight) will be applied by a screw jack on a plate at the bridge deck level. The plate will reach across the width of the bridge deck. The screw (30 mm diameter) must be able to reach the middle of the span of the bridge deck from directly above the bridge so leave a gap in any structure above the deck so that the loading screw can reach the deck.**
3. **The peak (highest) applied load that the bridge withstands will be measured electronically.**
4. **The winner is the bridge that holds the highest load before failure.**
5. **All bridges will be destroyed during testing!!!!!!!**

