

Testing Procedure

Load testing will begin at 11 am on Saturday, March 7th at Country Club Centre until all bridges are tested. Bridges are tested to failure, so remember to take your pictures early!

The loading platform will be suspended from each bridge deck as described in the previous pages. Weights will be continually added to the platform until the bridge collapses or deflects more than 50 mm in any direction. The last weight supported prior to failure will be recorded as that bridge's capacity.

Bridges will be ranked according to their final failure capacity and prizes will be awarded after all testing has been completed.

An Engineering Booth will be set up in the Country Club Centre on Feb 14 and 15 on Feb 21 and 22 and on Feb 28 and March 1 between 11:00 am and 3:00 pm to make bridge construction kits available and answer questions. Also during this time, bridge-building methods will be demonstrated on site. Contestants may buy building kits or submit completed bridges in the Country Club Centre during Administration Office hours in February and March up to the deadline.

Building materials are available in construction kits containing approximately 125 popsicle sticks, glue and construction paper to form a bridge deck. Kits can be purchased at the mall at a cost of \$2.00 each. Alternatively, popsicle sticks can be bought at Hobby/Craft stores.

2009 POPSICLE STICK BRIDGE BUILDING COMPETITION

BROUGHT TO YOU BY...



**THE ASSOCIATION OF
PROFESSIONAL ENGINEERS
AND GEOSCIENTISTS OF BC**

&

THE COUNTRY CLUB CENTRE

Location

Country Club Centre

March 7, 2009 start at 11 am

Contest Format

The contest is open to all interested groups and individuals with the competition divided into three categories:

- age 12 and under,
- ages 13 to 16, and
- ages 17 and over.

All contestants will receive an official certificate of participation.

Prizes Awarded for:

- the strongest three bridges in each of the three categories,
- the strongest overall bridge, and
- the most innovative design.

How to Enter

Bring your completed bridge to The Country Club Centre on or before March 7, 2008 during Country Club Centre Administration Office Hours, telephone 250 758 1102

YOUR MISSION

To build a bridge of popsicle sticks and glue that:

- carries the heaviest load,
- features an innovative design, and
- meets the requirements listed below.

Notes on Bridge Construction

The completed bridge is to contain a maximum of **100 popsicle sticks** joined together with **glue**. White glue is suggested, but other glues will also be allowed. Pinning or other connections will result in disqualification.

The bridge must be able to span **500 mm** (be more than 500 mm in length) and allow a matchbox car (50 mm wide x 40 mm in height) to roll across the bridge unimpeded without falling through. The driving surface is to be level; no significant incline or decline permitted.

As shown in the figure below, the bridge must be less than **100 mm wide**, **200 mm high**, and protrude no more than **50 mm** below the bottom of the bridge deck. The bridge must also be free from the support by **30 mm on each side**.

Questions? email to jhofman@rjc.ca or cwintle@eba.ca

This event brought to you as part of Engineering and Geoscience Week in BC. For more information on Engineers and what they do, check out:

<http://www.apeg.bc.ca>

<http://www.new-sng.com>

<http://bridgecontest.usma.edu/download.htm>

<http://jhu.edu/~virtlab/bridge/bridge.htm>

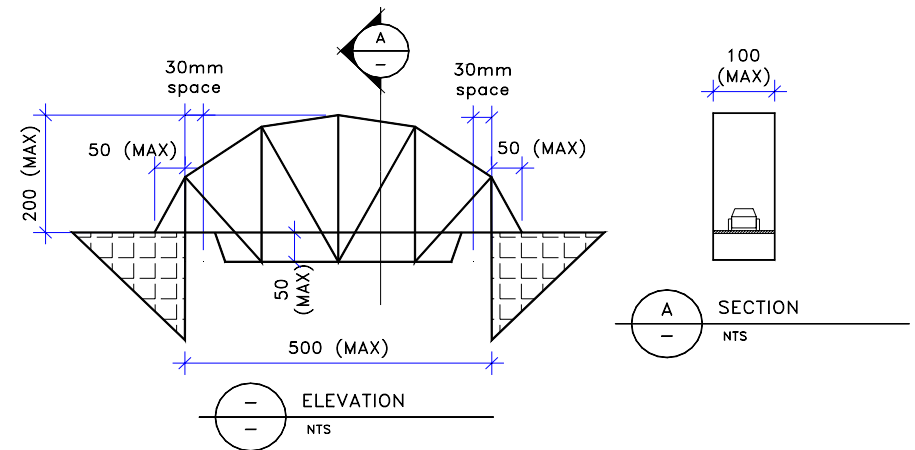

Bridge Load Testing

The bridge will be loaded via **one or two** loading bars. To accommodate the loading bars, **30 mm x 30 mm gaps** must be provided between the vertical members of the bridge – see the figures below. The gaps are to be continuous through the entire width of the bridge and must allow the bars to sit directly on the bridge deck.

