

Testing Procedure

Load testing will begin at 11 am on Saturday, March 3rd at Country Club Centre until all bridges are tested. Bridges are tested to failure, so remember to take your pictures early!

The loading platform will be suspended from each bridge deck as described in the previous pages. Weights will be continually added to the platform until the bridge collapses or deflects more than 50 mm in any direction. The last weight supported prior to failure will be recorded as that bridge's capacity.

Bridges will be ranked according to their final failure capacity and prizes will be awarded after all testing has been completed.

An Engineering Booth will be set up in the Country Club Centre on Feb 17 and 18 as well as Feb 24 and 25 between 11:00 am and 3:00 pm to sign up contestants and answer questions. Also during this time, bridge-building methods will be demonstrated on site. Contestants may sign up or submit completed bridges in the Country Club Centre during Administration Office hours in February and March up to the deadline.

There will be a **\$2 entry fee**. Upon registration contestants will receive a construction kit containing approximately 125 popsicle sticks and construction paper to form a bridge deck.

2007 POPSICLE STICK BRIDGE BUILDING COMPETITION

BROUGHT TO YOU BY...



THE ASSOCIATION OF
PROFESSIONAL ENGINEERS
AND GEOSCIENTISTS OF BC
&
THE COUNTRY CLUB CENTRE

Location

Country Club Centre March 3, 2007 start at 11 am

Contest Format

The contest is open to all interested groups and individuals with competition divided into three categories:

- age 12 and under,
- ages 13 to 16, and
- ages 17 and over.

All contestants will receive an official certificate of participation.

Prizes Awarded for:

- the strongest three bridges in each of the three categories,
- the strongest overall bridge, and
- the most innovative design.

How to Enter

Bring your completed bridge to The Country Club Centre on or before March 3, 2007 during Country Club Centre Administration Office Hours

YOUR MISSION

To build a bridge of popsicle sticks and glue that:

- carries the heaviest load,
- features an innovative design, and
- meets the requirements listed below.

Notes on Bridge Construction

The completed bridge is to contain a maximum of **100 popsicle sticks** joined together with **glue**. White glue is suggested, but other glues will also be allowed. Pinning or other connections will result in disqualification.

The bridge must be able to span **500 mm** (be more than 500 mm in length) and allow a matchbox car (50 mm wide x 40 mm in height) to roll across the bridge unimpeded without falling through. The driving surface is to be level; no incline or decline permitted.

As shown in the figure below, the bridge must be less than **100 mm wide**, **200 mm high**, and protrude no more than **50 mm** below the bottom of the bridge deck. The bridge must also be free from the support by **30 mm on each side**.

Questions? Send an email to jhofman@rjc.ca

This event brought to you as part of Engineering and Geoscience Week in BC. For more information on Engineers and what they do, check out:

<http://www.apeg.bc.ca/students.html>

<http://www.new-sng.com>

<http://www.generation-e.ca>

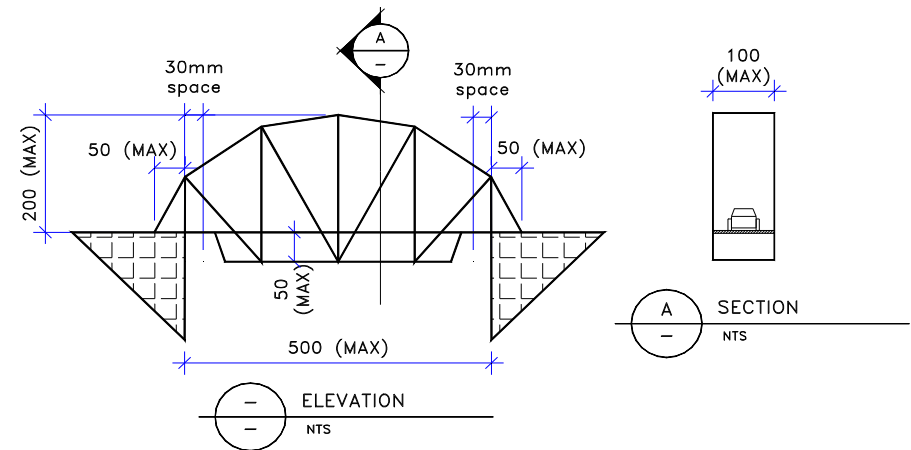

Bridge Load Testing

The bridge will be loaded via **one or two** loading bars. To accommodate the loading bars, **30 mm x 30 mm gaps** must be provided between the vertical members of the bridge – see the figures below. The gaps are to be continuous through the entire width of the bridge and must allow the bars to sit directly on the bridge deck.

